

HONDA ACCORD

Internationally acclaimed



HONDA **Accord**

Internationally acclaimed

Winner of numerous awards and



Honda Accord.
Two luxury,
performance cars
which measure up
perfectly to
today's motoring
requirements.

Each according to their needs. A sporty 3 door hatchback. Or a 4 door saloon. With the same engine, mechanical layout and instrumentation. And providing the same high standards of performance, steering, handling and ride.

There's a choice between a 5-speed manual gear box and the 2-speed Hondamatic system. Whatever the choice, you are assured of lively response from the transversely mounted 1602cc 4-cylinder overhead camshaft engine. And useful economy of 2-star fuel.

Precise and positive handling derives from advanced engineering with front wheel drive, independent suspension, rack-and-pinion steering, front disc brakes and dual braking system.

Improved features of the 1979 model include a fully transistorised ignition system. See now what else the Honda Accord has to offer.



Honda Accord
3 door.
Sporty performance in generous proportion.

Here is a hatchback that scores both in front and behind. Leg and head room are generous for front and rear passengers. And the fully reclinable, contoured front seats have built-in head restraints and tricot fabric inserts for all-weather comfort. They give positive support without interfering with shoulder movement and are adjustable fore and aft. Inertia reel seat belts, with 3-point fixing, are fitted as standard.

The wide opening, high lifting tail gate allows easy loading and unloading. It is self-locking and easily unlocked — either by

a lever near the driver's seat or with a key. Two telescopic dampers support the tail gate when lifted; and these fit neatly into the rear pillars when closed to allow unobstructed rear vision. In the luggage compartment, parcels and valuables are hidden from view by a two-piece sturdy rear parcel shelf. And the fully-carpeted rear luggage area is easily increased by folding down the rear seat. Featuring tinted glass all round, a laminated windscreen, halogen headlamps, rear fog lamps and steel belted radial tyres, the Accord 3 door lives up to its lively performance in style.

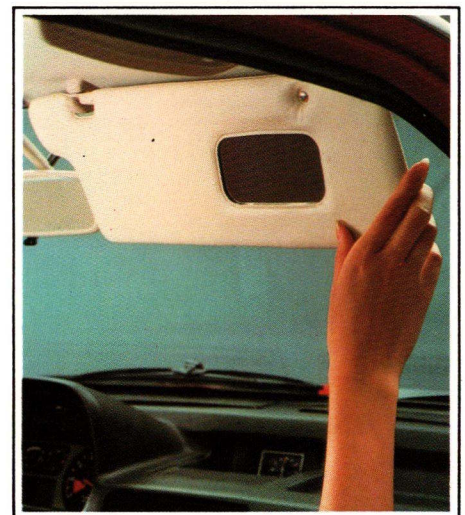
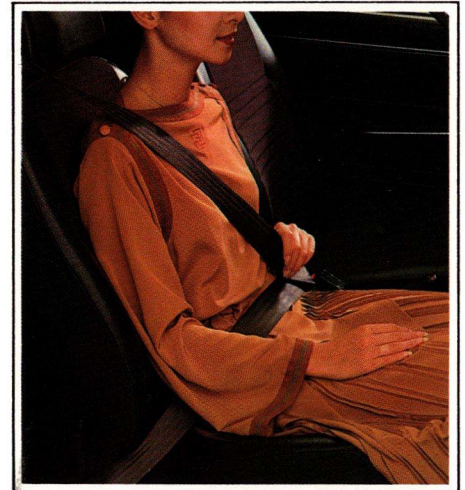
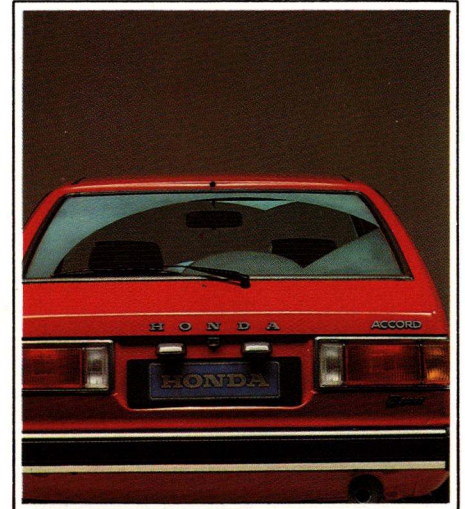

Honda Accord
4 door.
Compact
limousine luxury.

Modest external dimensions belie a spacious fully carpeted interior that provides ample room for four and sufficient room for five with the rear armrest down. The four full-size doors are fully trimmed and equipped with arm rests/door pulls and passenger grab handles. Door openers and window wipers are flush-fitted and the rear doors have child-proof safety locks.

Seating is as with the 3 door model plus two fixed head restraints and a central arm rest for the rear seat. Magazine pockets are incorporated at the rear of the

front seat. Illuminated ashtrays on the front passenger door and two rear doors are there for those who wish to light up. Further illumination is provided for the boot—one of the largest available for a saloon car of its size. The boot is lined with thick fabric and has two side pockets which can be opened either with a key or by a lever next to the driver's seat. Overall, the passenger compartment conveys an atmosphere of quiet comfort and discreet luxury... with everything that the 3 door has to offer in saloon car proportions.

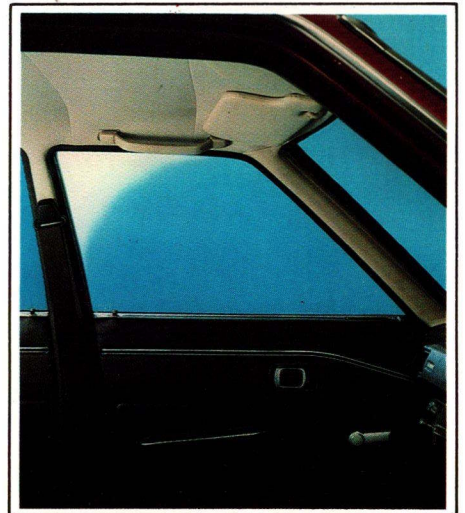
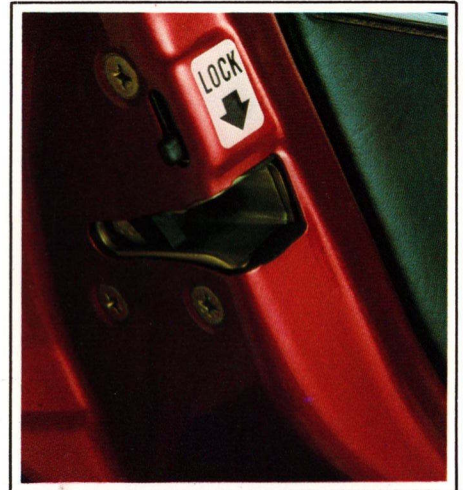
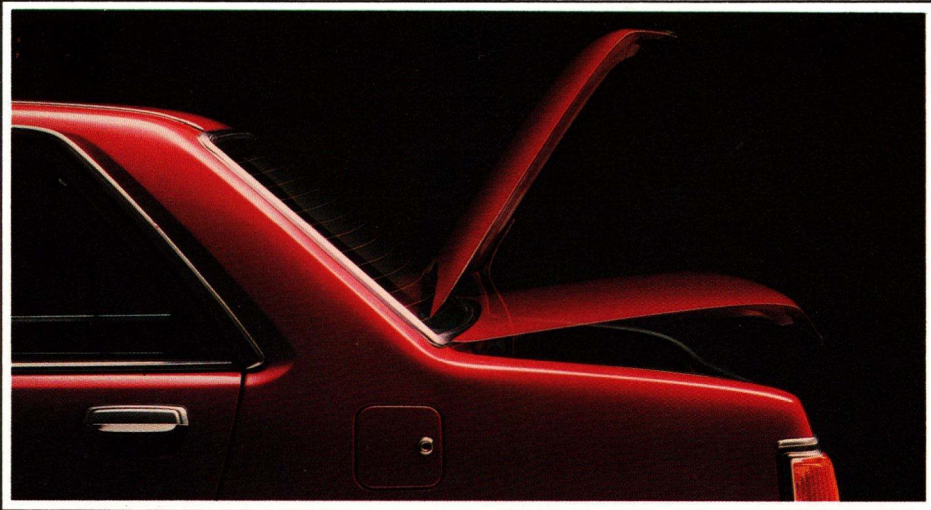

**Engineering
in Accord.
Power at your
command.**

Switch on with a fully transistorised ignition system that assures long-life performance without the need for periodic adjustments. And 80H.P. is at your command from an engine with the increased displacement of 1602cc. Providing even more power and response — particularly in the medium speed range.

The snappy five-speed gearbox gives you an extra ratio of enjoyment and is ideally matched for smooth power transfer at all speeds. The same applies with the 2-

speed Hondamatic system, available as an optional extra; and its lower gear enables you to take off in a hurry.

At high speed, you're completely in command . . . with rack-and-pinion steering that's light and positive . . . stability and road holding that is impressive. Hardly surprising: front wheel drive and transverse engine mounting in the light monocoque body makes possible a wider track and longer wheel base with a low centre of gravity. 4-wheel suspension, using McPherson strut long coil

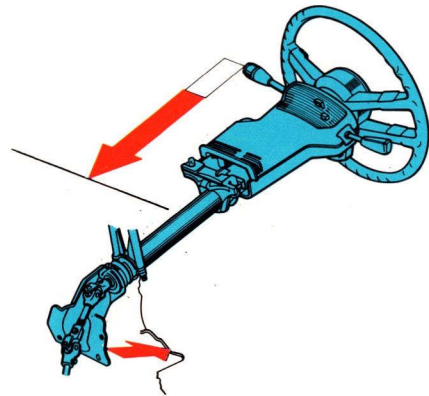
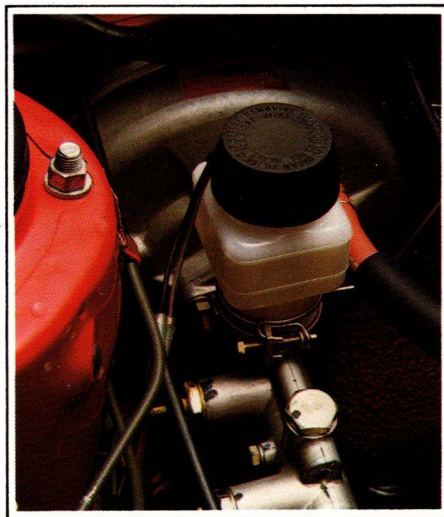
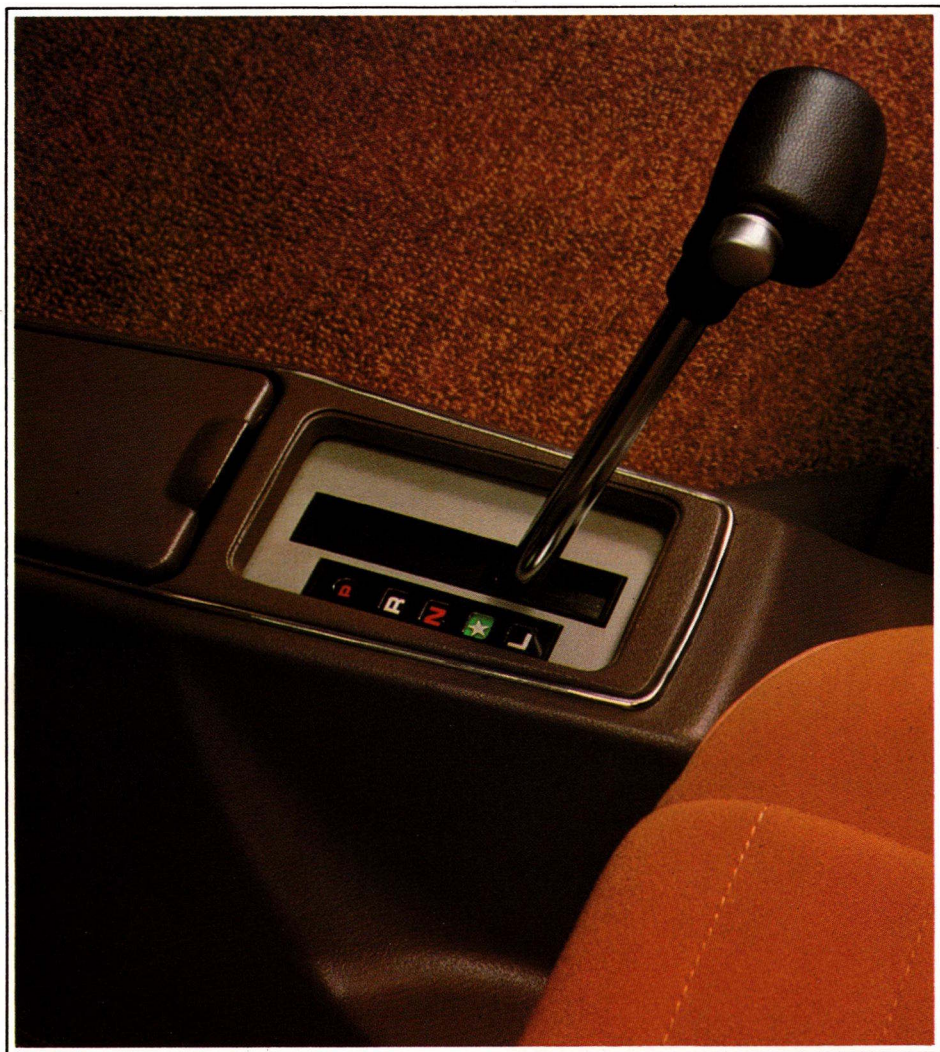

Collapsible steering column has telescopic top shaft.

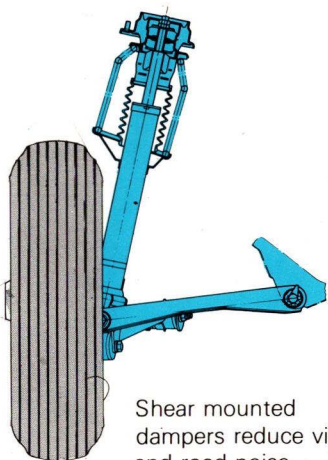

Shear mounted dampers reduce vibration and road noise. Rear suspension offset spring dampers reduce stress and improve riding comfort.

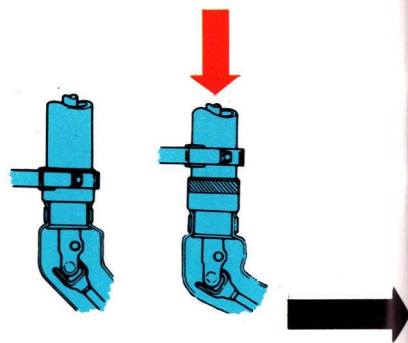
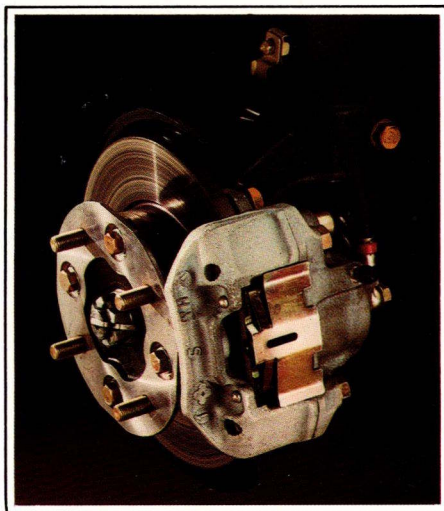

As a further measure to protection articulated two joint linkage has been provided.

suspension units brings an added bonus of superior handling and general riding comfort. And a smoother off-set spring rear suspension enhances ride stability and rear seat comfort. Going power. And stopping power. Completely at your command. A quick safe stop with the lightest of pedal pressures is yours for the asking . . . from servo-assisted hydraulic brakes with large diameter front discs and proportioned control valve (TCV) rear drums. Fail-safe operation is assured by a dual breaking system.

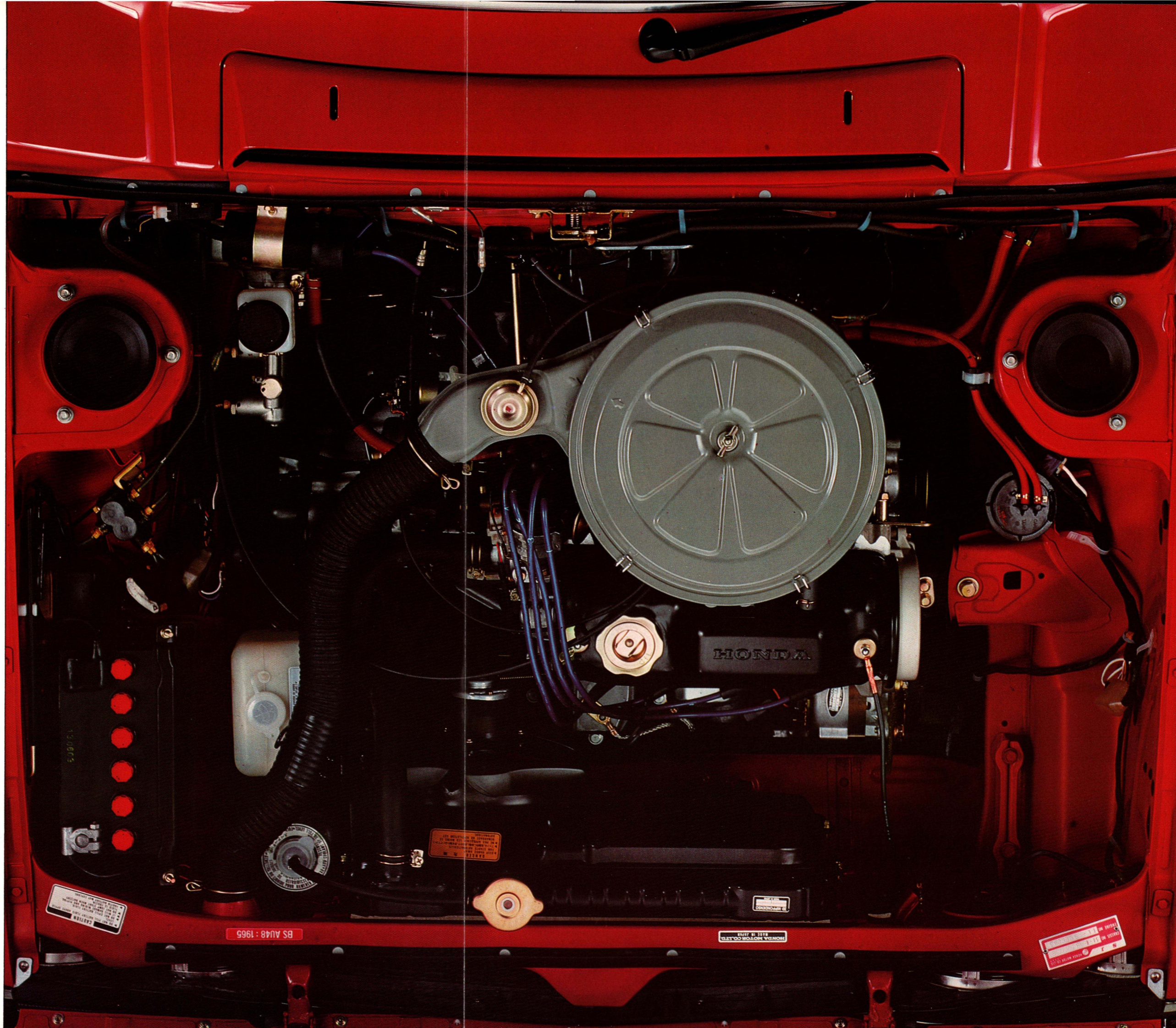
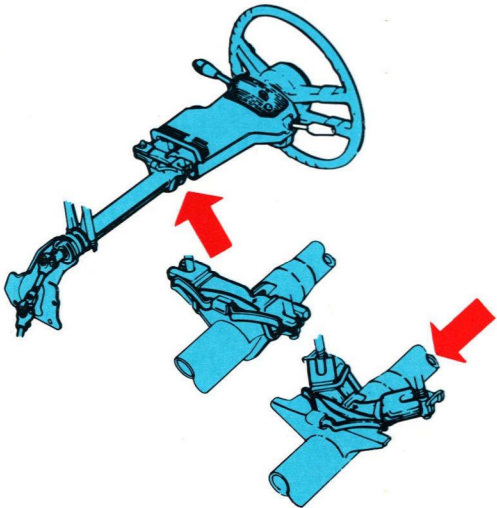
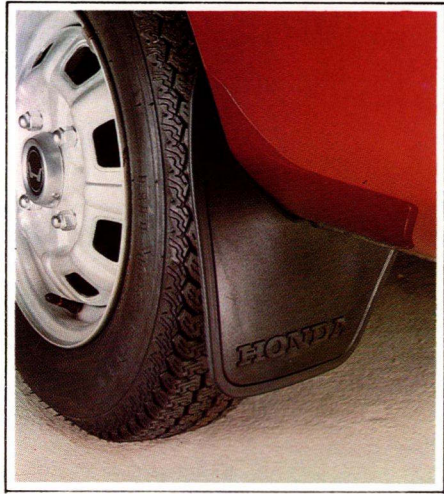
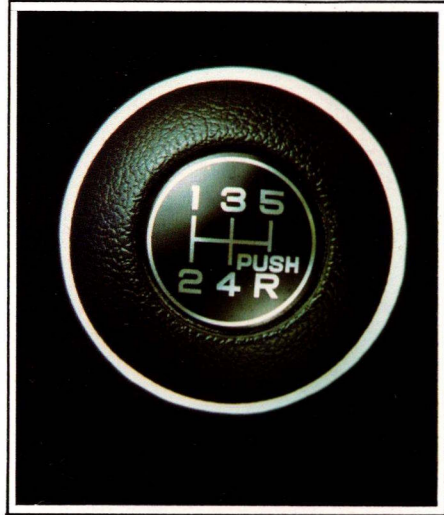



HONDA

Acclaim for Accord. What the international press has to say.

Somewhat up the market comes the Honda Accord, the nicest Japanese car I have driven and one which many manufacturers would have been pleased to produce.

Guardian

Look out BMW, Japan's Honda motor firm is setting out to give BMW quality and at much lower prices.

Honda's latest 4-door, 5-seat Accord saloon is packed with quality features to support this claim. The Accord is delightfully smooth, quiet and untiring to drive and has some superb features like: a maintenance warning system that indicates when oil needs changing, when the engine filter must be renewed and when tyres need rotating, and a safety indicator panel telling you when a brake light has failed and which one, or if a door or the boot is not properly shut. The driver can also unlock the 16 cu. ft. boot without leaving his seat.

The front-wheel drive Accord Saloon is powered by a 100 mph 1600cc transverse engine; heating demists side windows and rear foot wells and rear seats have neck restraints and a centre arm rest.

An excellent car at £3,495 (manual), or £3,695 (automatic) including tax.

Guardian

Fairly recently I was pontificating that often the price of good miles to the gallon figures was poor acceleration but with last weekend's test car, the Honda Accord four-door saloon, I discovered that it is possible to both have one's cake and eat it!

My own motoring over about 200 miles gave me an average of about 40 mpg.

**Dumfries & Galloway Standard
& Advertiser**

Our first impression of the Accord was its sheer air of quality and quietness. After the fast and furious nature of the Civic, which is a real boy racer's vehicle, the Accord surprised us with its sophisticated design.

With its 11 gallon tank the Honda is capable of covering an easy 350 miles on a tankfull and its 8.4:1 compression ratio demands only 91 octane (3 star) fuel, although you might get away with 2 star if you are a gentle driver.

Popular Motoring

Honda have always been non-conformist. Their little gem, the N600, revealed a flair in design and manners which began to flower in the Civic. Yet even that is packaged and suspended in a way that cannot quite match the better Europeans. However, their latest effort has ripened to rival the very best. In the fundamental areas of performance, economy, handling and ride, Honda have caught up with one dramatic stride and the Accord's package is pitched neatly midway between the practical, compact saloons and the fun-loving coupés in its market sector. Its designers knew precisely what they were aiming at and have proved devastatingly successful in achieving it.

There are still some hang-ups on view, like unacceptable noise at main road speeds and mediocre underbody rust protection. Rear seat accommodation may be acceptable by Capri standards but compares unfavourably with some saloon counterparts. Likewise, getting rear passengers and baggage in and out will disenchant the more pragmatic prospective owner.

For others, its stylish lines and ego-boosting image will outweigh these snags; they will consider its reasonable back seat and hatch back an appreciated bonus. There is absolutely no doubt in our minds that its road manners justify its sporty image — more discerning drivers will find it goes as well as it looks.

AA Road Test Report

And the best of the new, sophisticated bunch is a high-speed, sporty 1600cc model with an elegance usually found only in cars costing around £10,000.

The five-speed Honda Accord is aptly named.

For every silky-smooth control is exactly where you would expect it.

News of the World

In fact, at £3,495, it offers a standard of finish which is truly remarkable.

Mechanically similar to the 1978 3-door hatchback, the rear half of the new car has been redesigned to include two full sized rear passenger doors and a conventional boot. The result is a spacious, sporty looking saloon.

I must confess I was depressed by the Honda Accord. Thoroughly depressed in fact soon after I pulled out of the car park, and more depressed as I made my way Westward down the M4 with my travelling companion, a civil servant who lives a couple of doors away from me in Cookham.

Why depressed — because the Accord is so good.

Motor Trader

To European eyes, the Honda Accord looks like the best thing yet to come from Japan.

Apart from the clean styling, Honda have set a new Oriental standard for handling, comfort and general driver appeal — areas often neglected by their fellow-countrymen.

What is beyond dispute is that it is a driver's car. By that I mean that it has enough performance to be interesting plus handling and roadholding good enough to make Ulster byways a pleasure to press along.

Belfast Telegraph

Most outstanding of all the new Euro-Japs was the Honda Accord — car of the year in my book. For a little over £3,000 a well-engineered, lavishly-equipped driver's car with a practical hatchback.

Belfast Telegraph

For my money it is the best Japanese car yet to come here and well up with leaders from the European factories which have longer and fuller experience of turning out such models.

Taking it further up the field are thoughtful additions like warm air demisting ducts to the side windows, concealed inertia reel seat belts and a lever down by the driver's seat to open the hatchback tailgate without having to fiddle for a key every time.

While Japanese cars in general have not until now been noted for their sure handling, the Accord is designed European style with all-round independent suspension, rack and pinion steering and a transverse overhead camshaft engine driving the front wheels.

Motoring

**Instrumentation
in Accord.**
Comprehensive
and complete.

Forewarned is for safer motoring. And in the Honda Accord, all information dials, gauges and indicators are grouped together at eye level for quick-glance reading. Instrumentation that leaves nothing—but nothing—to chance.

The illuminated instrument binnacle comprises a tachometer, speedometer, fuel gauge and temperature gauge; and warning lights for open or half-closed doors or hatch back/boot, defective rear tail light bulbs, indicators, hand brake, oil pressure, ignition, choke, headlight high

beam and low fuel—plus tripometer reset knob. Impressive enough but we're not finished yet. Within the speedometer and connected to the milometer, is a maintenance indicator which tells you when the tyres are due for rotation and when the engine oil filter needs changing.

Elsewhere, on the right of the steering column is a single stalk in which the light controls are positioned. On the left, is a stalk for control of the 2-speed wipers, intermittent wipe and two electric wipers washers.

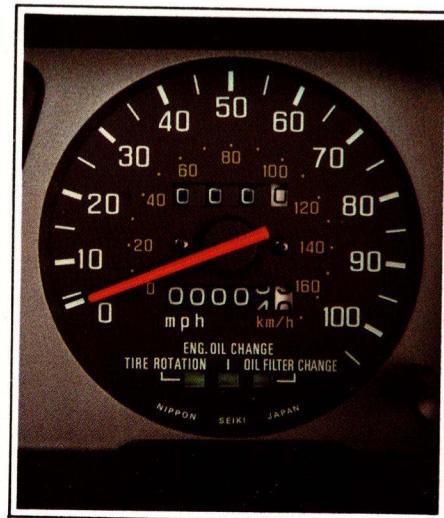
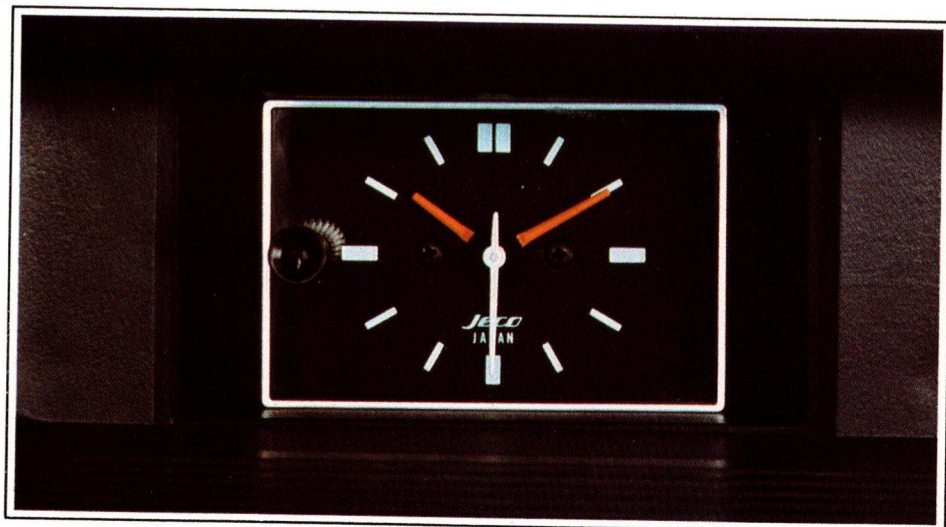
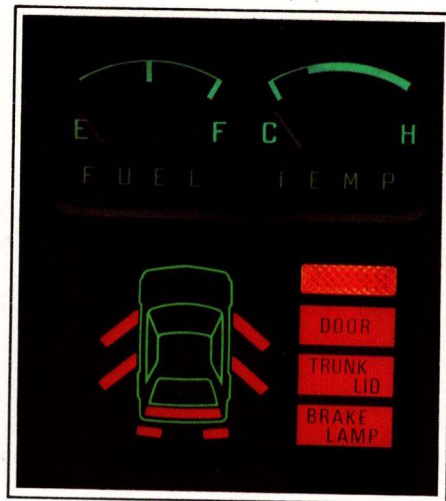

Heating and ventilation control and AM/FM radio are illuminated and located for ease of operation at the centre of the dashboard. Also on the dashboard are controls for the rear window washer/wiper, heated rear window, choke, and a rheostat which controls the amount of light on the instrument binnacle. And illuminated clock and cigarette lighter completes the dashboard array. Other than telling you when you're tired and need a break, the Honda Accord has instrumentation that tells you about everything.

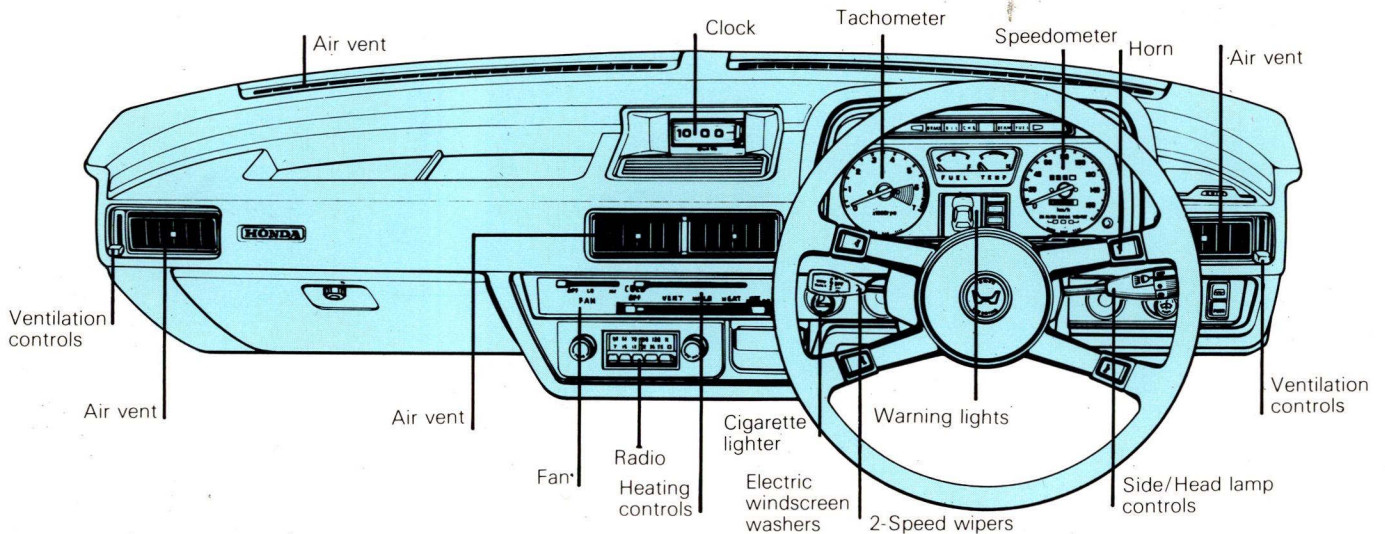

**Environment
of Accord.
Safety in comfort.**

The inside story of the Honda Accord is one of space technology with a difference: a wide, low shape that creates more space. The result? More seating width and shoulder room, allowing greater freedom of movement. And a large glass area for better all-round visibility and a comfortable feeling of spaciousness.

A beautifully controlled internal environment is assured by a heating and ventilating system of advanced design. It has a 3-speed booster fan and simple facia-mounted controls. The 3 door features

four facia level vents and two lower vents in the front foot well; and the 4 door has two additional air ducts to the rear foot well. Side window demisters, connected to the windscreen demister system, make a valuable contribution to driving safely during rainy weather and in wintry conditions.

And to complete the picture, a heated rear window is standard in both models.

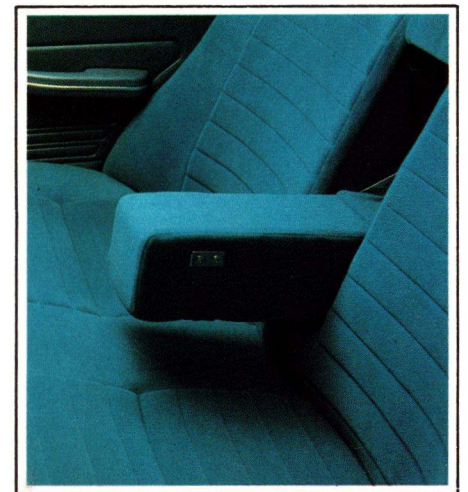
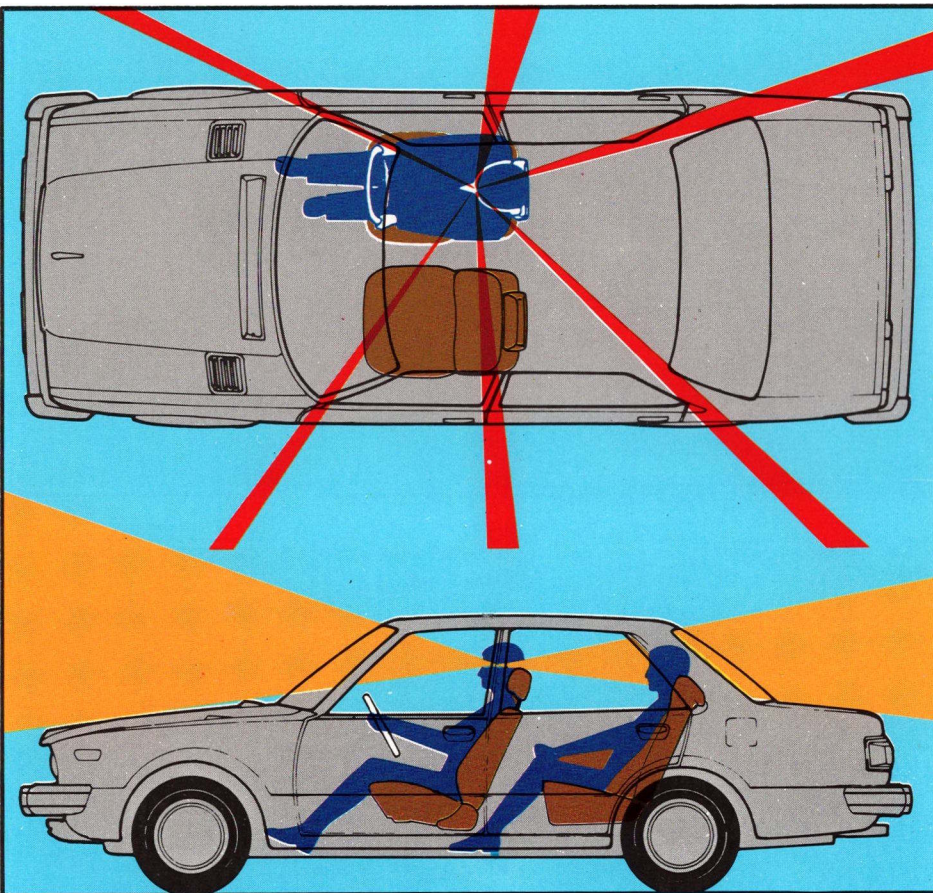
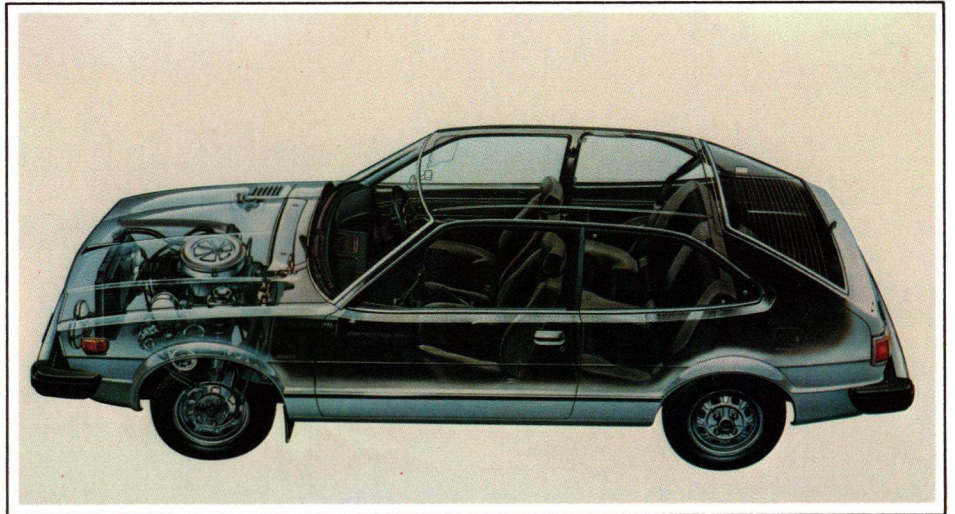
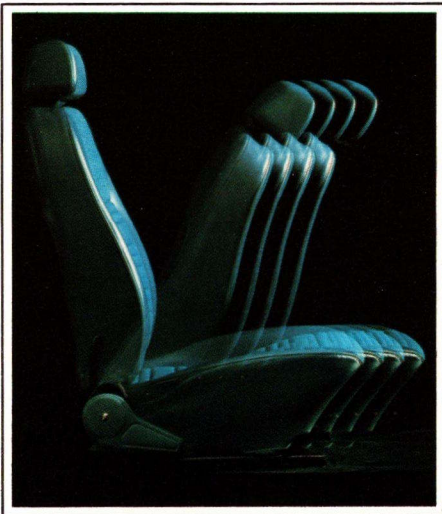

Top. Illustration shows minimal amount of obstructed vision.

Above. Illustration highlights excellent vision front and rear.

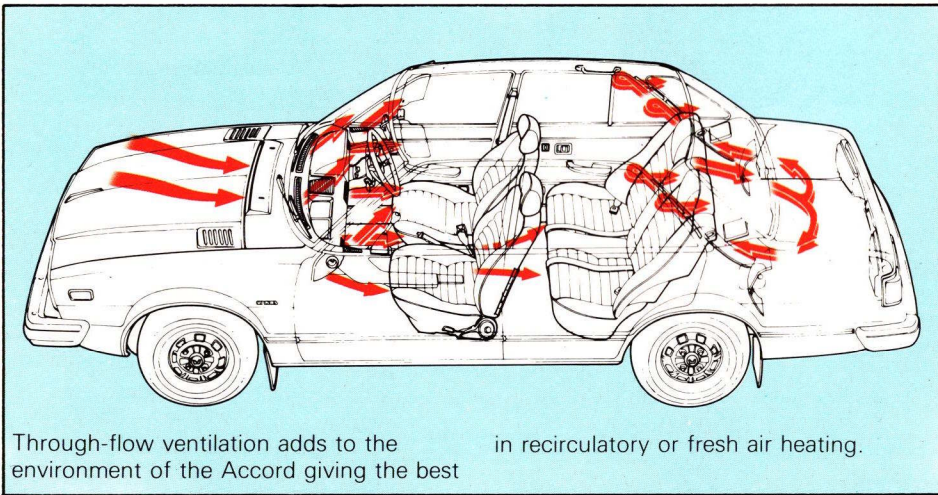
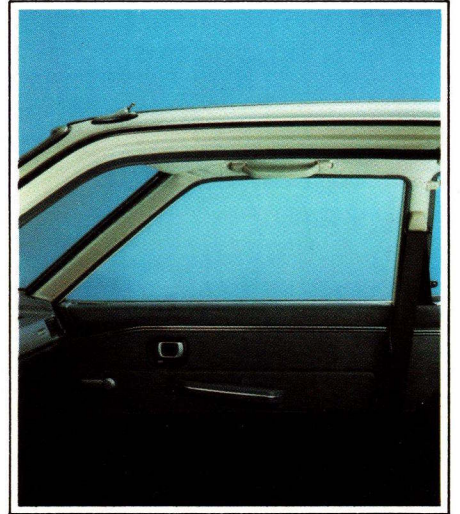
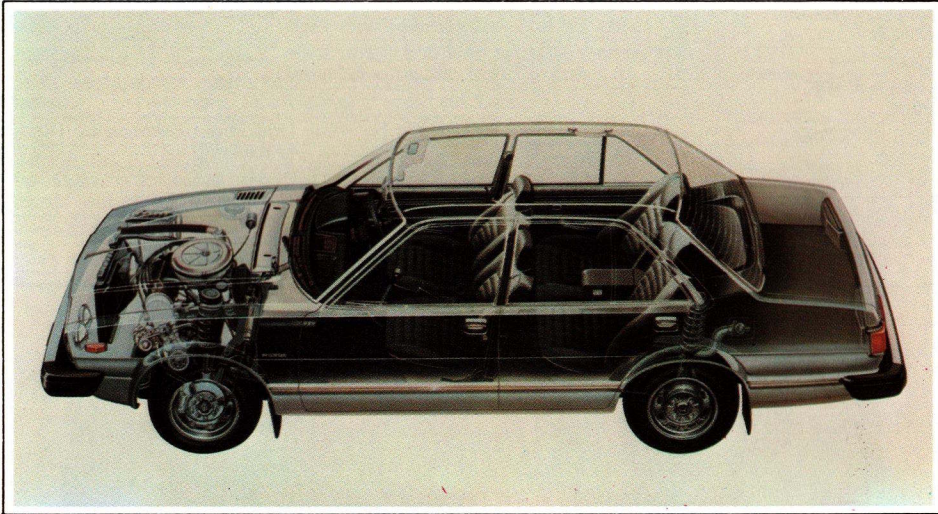

Through-flow ventilation adds to the environment of the Accord giving the best in recirculatory or fresh air heating.

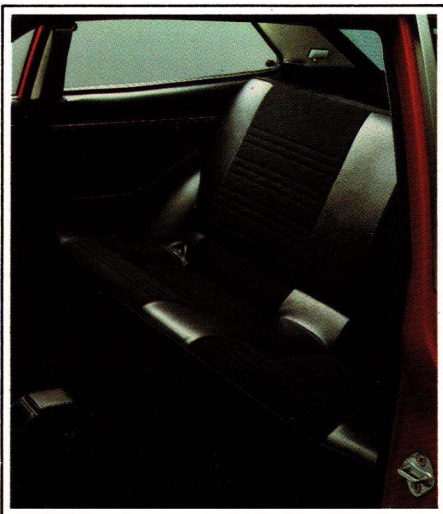
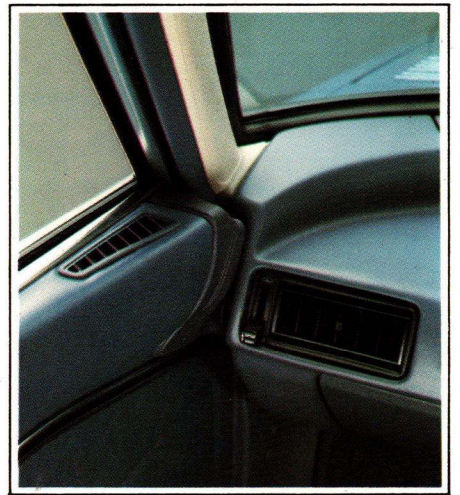

Standard Equipment

		3 DOOR	4 DOOR			3 DOOR	4 DOOR
EXTERIOR	Front glass	Tinted, laminated		Hand grips	Front passenger side/rear 2		
	Rear glass	Tinted with electric demister		Door armrests	Standard		Standard
	Door mirror	Driver's side		Child proof rear door locks	Standard		Standard
	Side moulding/protector	Standard	Standard	Carpet	Standard		Standard
	Bumper rubber corner pads	Standard		Boot/hatchback lever	Standard		Standard
	Mudguards front & rear	Front only	Standard	Luggage mat	Carpet		Fabric mat
				Trunk side pockets	Standard		Standard
INTERIOR	Seat	Full tricot upholstery		Glove box light	Standard		Standard
	Front	Reclining separate seats with adjustable head rests		Boot/hatchback area light	Standard		Standard
	Rear	Folding	Bench seat with headrests and centre armrest	Rear fog lamp	Standard		Standard
	Seat belts	Inertia reel. Three point fixing		ELECTRICAL SYSTEM	Wiper	2 speed & intermittent	
	2 Magazine racks	Standard			Electrical Windshield washer	Standard	
	Inside rear view mirror	Day/night brake away system		Twin band radio	Standard		Standard
	2 sun visors	Pivoting, vanity mirror on passenger's side		Clock	Electric		
	Steering	Collapsible with lock		Heater	3 speed fan		Rear seat heater duct
	Choke	3 position manual with warning lamp		Meters	Speedometer, tachometer fuel meter, temperature meter, tripmeter		
	Maintenance indicator	Tyre rotation, oil change, oil filter change		Safety indicator	Door, boot/hatchback, brake lamp		
	Centre console	Standard		Pilot lamps	Choke, brake, oil pressure, oil level, charge, beam, fuel, hazard		
	Ashtrays	2 front 1 rear	2 front 2 rear	Cigarette lighter	Standard		Standard
	Side demister	Standard		Heater panel illumination	Standard		Standard

Dimensions 3 door.

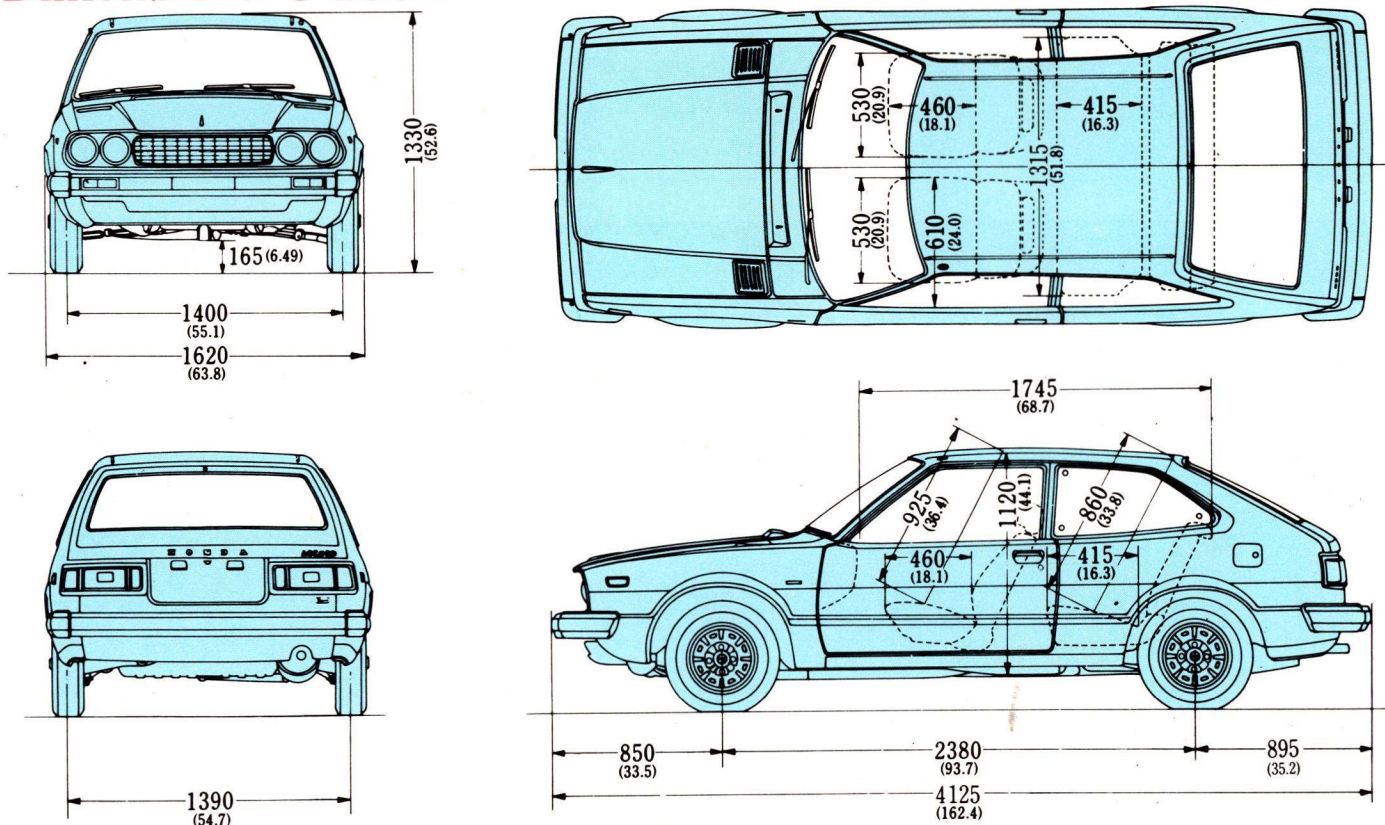

Colours 3 door.

Please note due to printing process limitations the colours shown here may show a slight difference from the actual paint colour.

St. Moritz
Silver
Metallic



Montparnasse
Blue
Metallic

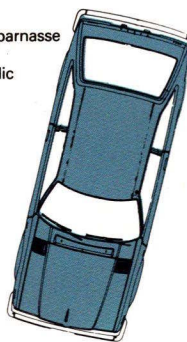

Livorno
Beige

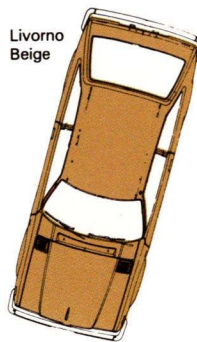

Valencia
Red
Metallic

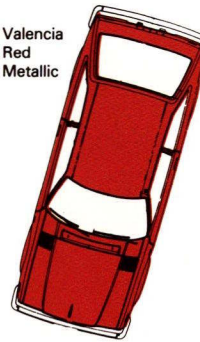

Sanremo
Green
Metallic

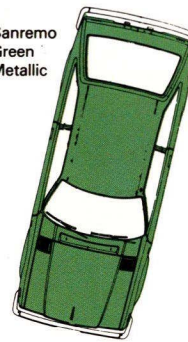

The white three-door car shown in this brochure is not available in the United Kingdom.

Specifications

	3 DOOR	4 DOOR
Engine	4	
Bore x Stroke	77mm x 86mm	
Cubic capacity	1602cc	
Max. Output	80 PS at 5,300 rpm DIN	
Max. Torque	12.9 kgm at 3,700 rpm	
Compression ratio	8.4 to 1	
Valve position/number of cams	Single OHC Tooth Belt Drive	
Carburettor	Keihin One-twin choke 20/26	
Transmission	Manual or automatic. Manual gear ratios: 5th 0.718, 4th 0.896, 3rd 1.200, 2nd 1.842, 1st 3.181, Rev 3.000. Automatic transmission: Hondamatic. Automatic gear ratios: 2nd 0.003, 1st 1.565, Rev 2.045. Type of final drive: Helical Top gear/1,000 rpm: Manual 21.1 mph. Automatic 17.6 mph. Final reduction ratio: Manual 4.384 Automatic 4.117	
Suspension Front/rear	Independent Macpherson strut and coil spring	
Steering	Rack and pinion with collapsible steering wheel column and steering lock	
Brakes	Hydraulic servo assisted	
Front	7.4 ins self adjusting discs	
Rear	Drum type leading trailing drum with PC valve Total metal area rubbed by pads/linings: 158.5 sq.ins. Parking brake hand operated mechanical	
Dimensions Overall length	162.4 ins (4125 mm)	171.1 ins (4345 mm)
Overall width	63.8 ins (1620 mm)	

	3 DOOR	4 DOOR
Overall height (unladen)	52.6 ins (1335 mm)	53.5 ins (1360 mm)
Wheelbase	93.7 ins (2380 mm)	
Front track	55.1 ins (1400 mm)	
Rear track	54.7 ins (1390 mm)	
Ground clearance	6.49 ins (165 mm)	6.69 ins (170 mm)
Turning circle	32 ft 5 ins	
Unladen weight	1962 lbs (890 kg)	2051 lbs (930 kg)
Maximum payload	1100 lbs	
Cubic capacity of boot	12.95 cu ft	15.97 cu ft
Tyre size/type	155 x 13 Radial tubeless	
Tyre pressures (lbs/sq ins)	Front 24 Rear 24	
Rim width	4½ J	
Fuel tank capacity	11 gallons (50 litres)	
Water coolant capacity	10 pts	
Oil sump capacity	6.5 pts	

Dimensions 4 door.

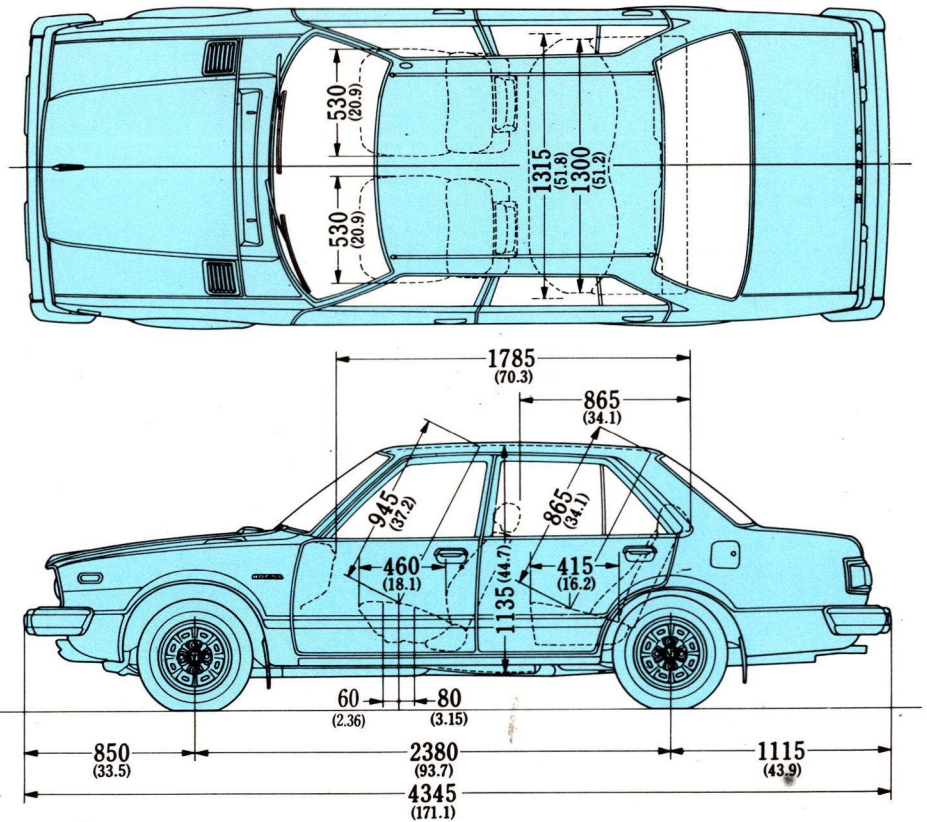
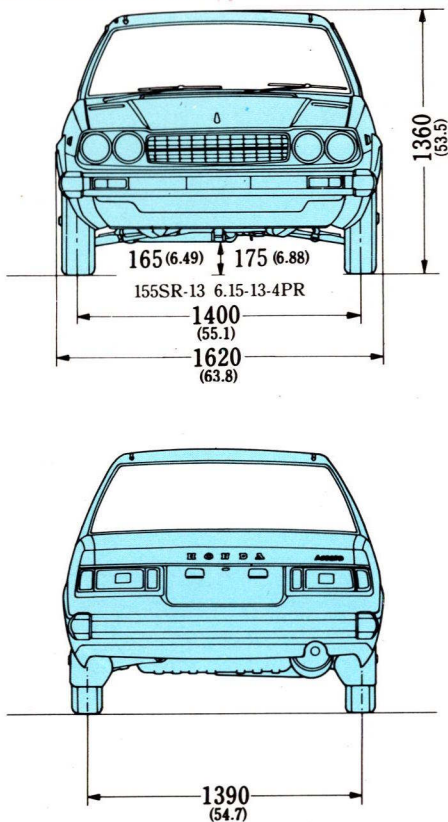

Colours 4 door.

Please note due to printing process limitations the colours shown here may show a slight difference from the actual paint colour.

St. Moritz
Silver
Metallic



Elysees
Bronze
Metallic

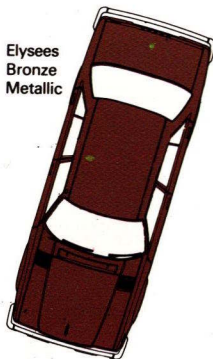

Livorno
Beige

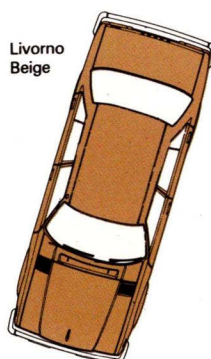

Shetland
White

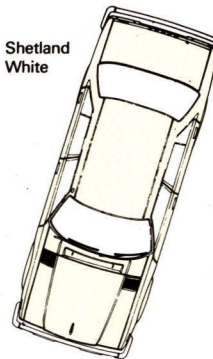

Sanremo
Green
Metallic

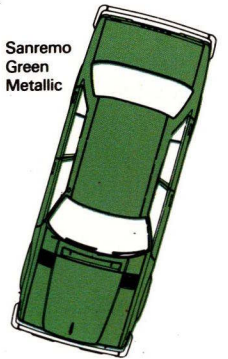

The red four-door car shown in this brochure is not available in the United Kingdom.

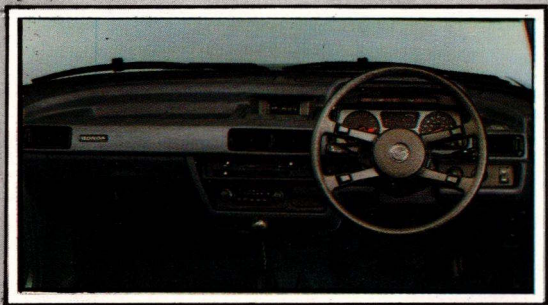

Your Honda Accord Dealer

"These specification details do not apply to any particular product which is supplied or offered for sale. The manufacturers reserve the right to vary their specification with or without notice and at such times and in such manner as they think fit. Major as well as minor changes may be involved. Every effort, however, is made to ensure the accuracy of the particulars contained in this brochure. Consult the Dealer with whom your order is placed for details of the specification of any particular product. This publication shall not constitute in any circumstances whatsoever an offer by the Company to any person. All sales are made by the Distributor or Dealer concerned subject to and with the benefit of the standard Conditions of Sale and Warranty given by the Distributor or Dealer, copies of which may be obtained from him on request."

Designed and Produced by Tarryoak Creative Services.

**Honda UK Ltd, Power Road, Chiswick, London W4 5YT.
Telephone: 01-995 9381**