

EXPORT

16 OKT. 1946

SERIES • E

The
MORRIS
E I G H T



The
MORRIS
EIGHT
(SERIES "E")

NOVEMBER, 1945
THIS LIST CANCELS
ALL PREVIOUS LISTS

NUFFIELD EXPORTS LIMITED

VISCOUNT NUFFIELD, G.B.E. *Chairman*
SIR MILES THOMAS, D.F.C. *Vice-Chairman*
S. G. K. SMALLBONE *Managing Director*

COWLEY - OXFORD - ENGLAND

OUTSTANDING FEATURES OF THE MORRIS EIGHT

- Outstanding road performance.
- Extreme economy.
- Attractive body design.
- Excellent accommodation.
- Modern engine with high performance.
- Four-speed gearbox with synchromesh on second, third and top gears, and silent helical pinions.
- Superb controllability with exceptionally light and accurate steering which is particularly free from road shock reaction.
- Well tried semi-elliptic springing controlled by piston-type hydraulic shock absorbers.
- Sound-insulated bodies free from objectionable drumming and creaks.
- Floating insulated engine mounting.
- Tin-coated aluminium alloy pistons, ensuring absence of pick-up and scoring.
- High efficiency safe braking by the Lockheed hydraulic fully compensated system.
- Extensive control over ventilation by bottom-opening windscreen with central winding control.
- Engine air silencer.
- Extensive crankcase ventilation with fume discharge below body.
- Good ground clearance.
- Scientific intake manifold giving increased power, economy and easy starting.
- Toughened Triplex glass throughout.
- Large inbuilt luggage container with external access.
- Well-less floor.
- Adjustable easy-chair front seats with floating cushions.
- Flush-type sliding roof with concealed drainage.
- Wide doors with concealed metal door stops.
- Special provision against draughts by draught welts round doors.
- Special weatherproofing by extended guttering discharging water below doors.
- Pleasing fascia board with conveniently grouped instruments having high location for ease of vision.
- Large parcel tray with level floor extending full width of car beneath fascia board.
- Projection-free hand brake with simple adjustment from driver's seat and fully enclosed grease-packed cables.
- Windscreen wiper with silent remote drive.
- Good rear vision by internal mirror and large rear light.
- Windscreen carefully sloped to reduce glare to a minimum.
- Counterbalanced crankshaft with steel backed main and big-end bearings.
- High capacity engine lubrication.
- Single-plate dry clutch with light action and smooth pick-up.
- Sturdy rear axle assembled by a scientific system of erection.
- Locked bonnet with hinged top.
- Spring anchorage by silent-bloc bushes; shackles fitted with Harris type bushes.
- Improved spoked disc easy-clean wheels with snap-on covers and six-stud fixing.
- Six-volt battery with positive earth wiring. Battery mounted on dash.
- All-weather protection for brake gear.
- Generous mudguarding of modern design.
- Corner jack, simple in operation.
- Self-cancelling Trafficators with steering wheel centre control.
- One-piece exhaust system flexibly mounted from frame.
- Large dynamo with compensated voltage control.
- Powerful inbuilt headlamps with dip and switch with foot control and pilot side bulbs.
- Automatic ignition control.
- Rear blind on closed models with remote control.
- Anti-fraying, bonded pile carpets.
- Full width bumpers front and rear.
- Large low-pressure tyres.
- Number-plate illumination with reflector device to facilitate reversing.

SPECIFICATION

GENERAL CONSTRUCTION. The Morris Eight (Series "E") car consists of a powerful side-valve engine built in unit construction with a four-speed synchromesh gearbox, mounted on a chassis of advanced design, with double-box section side members of exceptional strength.

Transmission is by Spicer tubular propeller shaft with needle type universal joints, and the rear axle is of the three-quarter floating type with spiral bevel final reduction gears and differential. Suspension is by long semi-elliptic springs, controlled by piston type hydraulic shock absorbers. The wheelbase is 7 ft. 5 in. and the track 3 ft. 8 $\frac{3}{8}$ in. at the front and 3 ft. 10 $\frac{1}{4}$ in. at the rear.

ENGINE. The four-cylinder side-valve engine of the Morris Eight (Series "E") possesses a bore of 57 mm. and a stroke of 90 mm. (3.54 in.), giving a cubic capacity of 918 c.c.

The cylinders are cast in one with the skirt of the crankcase, which is liberally reinforced with internal webs to provide a structure of great strength and rigidity. The crankshaft is of the counterbalanced type with three large bearings, ensuring freedom from vibration. Every crankshaft is carefully balanced to very close limits, and the main bearings have steel backed white metal liners.

The connecting rods are of steel with full-ring steel backed replaceable white metal bearings. They are carefully balanced individually, and the complete assemblies of connecting rods and pistons are equalised in weight to within 0.2 oz., as in best aero engine practice.

The pistons are of low expansion aluminium alloy, and they are fitted with three rings—two compression and one oil control. The pistons are tin-coated to ensure freedom from "pick-up" and have split skirts.

The valves are operated from a three-bearing camshaft situated in the upper portion of the crankcase. The camshaft is driven by a silent duplex roller chain which provides a trouble-free drive possessing very long life.

Hollow chill cast tappets of large diameter are fitted.

Valve adjustment is by adjustable screws on the valve tappets.

There is a large breather pipe discharging well below the body which ensures perfect crankcase ventilation and avoids condensation.

The engine is mounted on the chassis by floating rubber connections which effectively damp out the least trace of engine vibration, and the one-piece exhaust system is also flexibly mounted on the chassis.

SYNCHROMESH GEARBOX. The four-speed gearbox is provided with synchromesh engagement for second, third and fourth gears, which are of the silent helical type. The gearbox is fitted with an accessible filling orifice and a dipstick oil level indicator. The gear ratios are: 1st, 20.88; 2nd, 12.158; 3rd, 8.140; 4th, 5.286; reverse, 20.88.

LUBRICATION SYSTEM. A large spur gear pump located in the sump and driven by helical gears from the camshaft supplies oil under pressure to all main bearings, big-end bearings and camshaft bearings. The delivery from the oil pump is sufficiently large to ensure adequate lubrication, even under unfavourable conditions.

The oil intake in the sump is protected by a metal shield and extended oil intake pipe, and also provided with a cylindrical gauze filter. The pump is fitted with a non-adjustable relief valve. The chassis is lubricated by high pressure oil-gun and accessibly located nipples.

COOLING SYSTEM. The cooling water is circulated by thermo-syphon action. The water passages are carefully proportioned to ensure even cooling. A cooling fan is fitted.

CARBURATION. An S.U. automatic piston type carburetter, with adequate control over mixture strength for easy starting, supplies the working mixture. The mixture control is conveniently mounted on the fascia board and is inter-connected with the throttle control so that the correct throttle opening for slow running when cold is obtained automatically. The carburetter is provided with an efficient air silencer.

Particular attention has been given to the carburation system with a view to giving maximum economy without the sacrifice of performance. The induction manifold provides excellent distribution and is provided with an adequate "hot-spot." The fuel feed is by S.U. automatic electric pressure petrol pump.

PETROL TANK. The petrol tank is mounted at the rear of the chassis and has a capacity of 5 $\frac{1}{2}$ gallons. Its contents are clearly indicated by an electrically operated gauge on the fascia board, and the tank is fitted with a large vent to facilitate rapid filling.

TRANSMISSION. A single-plate dry clutch with cushion hub and single-point adjustment provides smooth engagement with light action and the minimum attention. A Spicer tubular propeller shaft with needle type universal joints at each end serves to transmit the drive to the rear axle.

REAR AXLE. The rear axle is of the three-quarter floating type with spiral bevel final reduction gears.

A scientific system of gear selection and assembly is employed to ensure maximum efficiency.

FOUR-WHEEL BRAKES. Fully compensated foot brakes of the internally expanding type, operated by the Lockheed hydraulic system, ensure the maximum possible braking efficiency. Their certainty of action is maintained under all conditions, as there are no bearings to wear or need lubrication, or cables to stretch. The brake-shoes are of steel, and lined with high efficiency linings.

The hand brake is provided with adjustment from the driver's seat and operates on the rear wheels by cables totally enclosed in grease packed conduits. Special provision has been made to protect the brake gear against the weather.

STEERING. The steering gear is of the cam type and careful design of all the steering components has resulted in exceptionally light steering which is particularly suited to lady drivers. In spite of the lightness of the steering, it is precise in action and free from any tendency to wander. The steering is also particularly free from road shock reaction.

SUSPENSION. Semi-elliptic springs of great length are fitted fore and aft and are controlled by hydraulic piston-type shock absorbers. The front spring eyes are fitted with silent-bloc bushes, and the shackle pins at the rear ends of the springs are fitted with Harris bushes, ensuring long life and the minimum of service attention.

WHEELS. Five detachable spoked-disc easy-clean wheels with Dunlop tyres (4.50—17) are fitted. The wheels are held in position by six studs with nuts of the reversible type and are fitted with snap-on hub covers. The spare wheel is carried in a separate compartment at the rear and is completely protected from the weather. It is easily removed.

VENTILATION. Special care has been taken to ensure adequate ventilation. The windscreen on the saloons has top hinges and is adjustable up to a wide opening by a single central control of the winding type. The windscreen can be opened to a wide angle for clear vision in fog. All door-windows are of the winding type.

SEATING ACCOMMODATION. The front seats are built on a steel framework with a floating spring foundation for the upholstery, ensuring the maximum riding comfort. The driving seat of the four-door saloon is mounted on flush type runners and has a simple and positive means for adjusting the position. The passenger's seat is also adjustable for position. Exceptionally good leg room is provided for the rear passengers, while the wide rear seat is upholstered on particularly generous lines and has an elbow width of 47 in.

JACKING SYSTEM. The standard jack equipment consists of a special corner jack adapted to hook under the bumper bar brackets and is equipped with a screwed shaft which can be actuated by the wheel brace. This jack is conveniently housed on the dash.

LUGGAGE ACCOMMODATION. The Morris Eight (Series "E") is fitted with a large inbuilt luggage compartment with external access by a large hinged lid. With the lid closed, the space available for storage is nearly $5\frac{1}{2}$ cubic feet. Special provision has been made to render the luggage compartment watertight. In addition there is a large parcel tray beneath the fascia board which extends the full width of the car. This parcel tray has a level floor.

ELECTRICAL EQUIPMENT. The electrical equipment is of the 6-volt type. The distributor has automatic advance and retard control and is driven from the camshaft by helical gears. The large dynamo is belt driven and is fitted with compensated voltage control. The positive earth system of wiring is employed. The starter motor is of ample capacity to ensure an instantaneous start under the most trying conditions, and its engagement is by sliding pinion. The starter switch is hand operated and located on the fascia board. Special three-lamp equipment is provided, including sunk headlamps with dip and switch mechanism operated by a single-acting foot-controlled switch which

dips the lights on one depression and raises them on the next. The sidelamp bulbs are incorporated in the headlamps.

The horn push and self-cancelling Trafficator switches are mounted in the centre of the steering wheel, while all other switches are accessibly mounted on the fascia board within easy reach of the driver.

An easily controlled windscreen wiper with silent drive and motor located on the engine side of the dash is fitted.

The single large 6-volt battery is mounted under the bonnet on the dash bulkhead. It is easily accessible and is provided with non-spilling vents.

An automatically actuated stop light is part of the equipment.

THE BODY. The floor is devoid of footwells and the interior is unusually spacious for a car of this horse-power.

Great care has been taken to prevent noise, draughts and the ingress of water. The body is scientifically lined with sound-deadening material, and the front of the body is constructed so as to isolate the body from engine heat and fumes. The doors are fitted with an efficient draught sealing strip, and the roof guttering is carried right down in front of the door opening to discharge rain water well below the door.

Door-window garnish frames are prepared in modern plastic material of attractive appearance and great durability, with fascia board to match.

Pile carpets of the anti-fraying bonded type cover the floor, while the interior upholstery is carried out in simple but pleasing style, and is particularly comfortable.

The instrument equipment includes oil gauge, speedometer and electric petrol gauge, all of which are provided with translucent indirect illumination.

GENERAL EQUIPMENT. Lockheed hydraulic brakes; pile carpets; gearbox draught excluder; dial-type speedometer; oil gauge; S.U. electric pressure petrol pump; dash-reading electric petrol gauge; electric windscreen wiper; pressure chassis lubricating pump; electric horn; electric lighting and starting; headlamps with dipping mechanism and pilot bulbs; stop lamp; self-cancelling Trafficators; bumpers front and rear; hydraulic shock absorbers; five detachable spoked disc easy-clean wheels; five Dunlop cord tyres; tyre pump; kit of tools; single-panel adjustable windscreen and winding door-windows of toughened Triplex glass; interior driving mirror; rear blind with remote control; private locks to doors; inbuilt luggage container.

Supplementary Equipment on Four-Door Saloon (F.H.). Easy-chair type front seats, sliding driver's seat, adjustable passenger's seat.

Supplementary Equipment on Four-Door Saloon (S.H.). Flush sliding head, easy-chair type front seats, sliding driver's seat, adjustable passenger's seat.

Supplementary Equipment on Two-Door Saloon (F.H.). Easy-chair type tip-up adjustable front seats.

Supplementary Equipment on Two-Door Saloon (S.H.). Flush sliding head, easy-chair type tip-up adjustable front seats.

This specification is liable to alteration at any time.

The

MORRIS EIGHT (SERIES "E") TWO-DOOR SALOON

DESIGNED to meet the requirements of those who desire a saloon car with a high degree of comfort for two persons and equally comfortable seating for two additional passengers on occasion, this Morris model provides the most economical closed-car motoring available to-day.

Attractive in appearance, with wide doors giving easy access to the front seats, commodious inbuilt luggage accommodation having external access, and seating space above the ordinary for a car of this horse-power, the Morris Eight Two-Door Saloon is remarkable value when compared with other cars in this power class.

It is available, until further notice, finished in Black with Brown upholstery only. Both the fixed head saloon and the sliding head saloon are upholstered in leather.

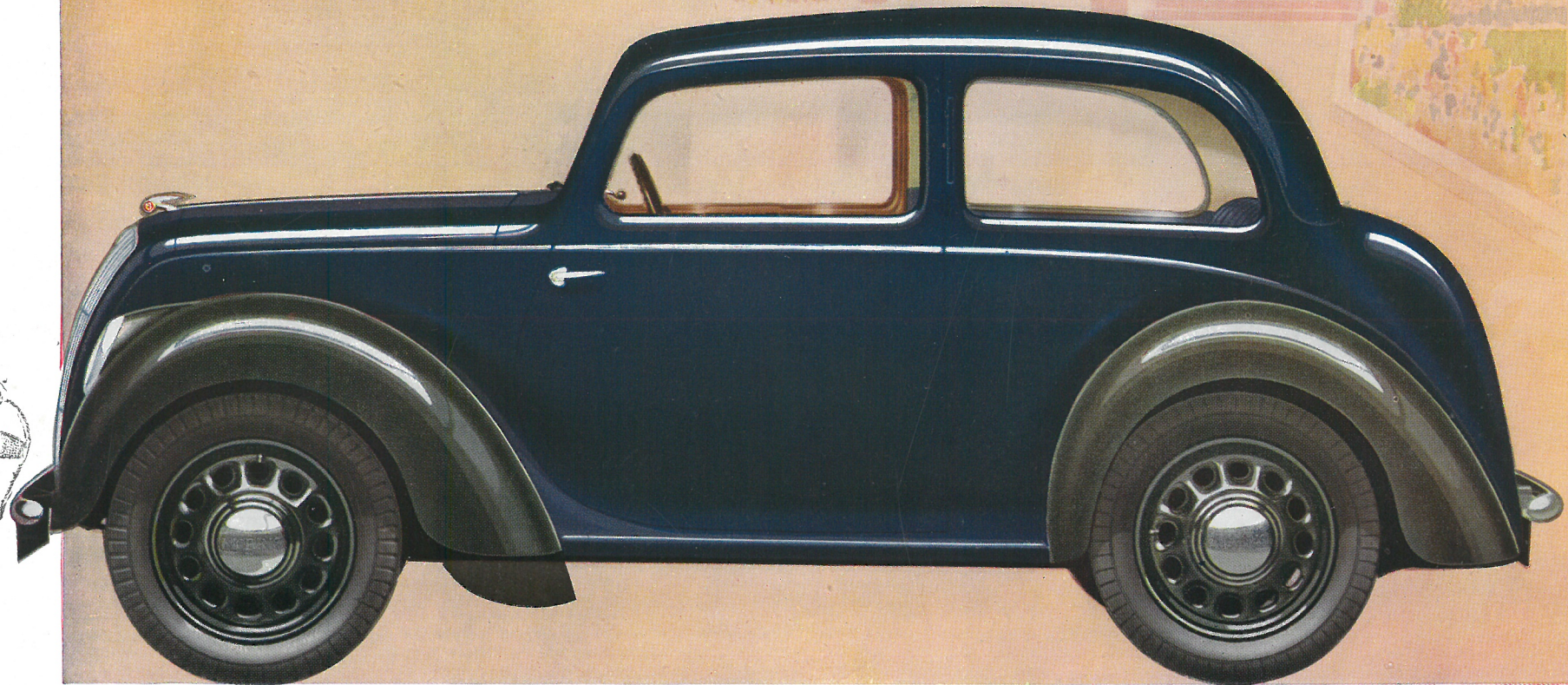
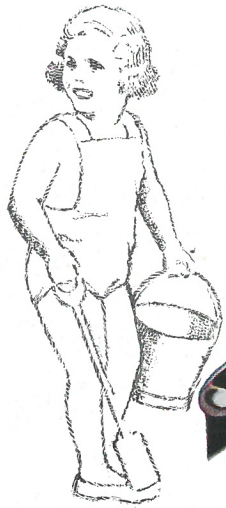

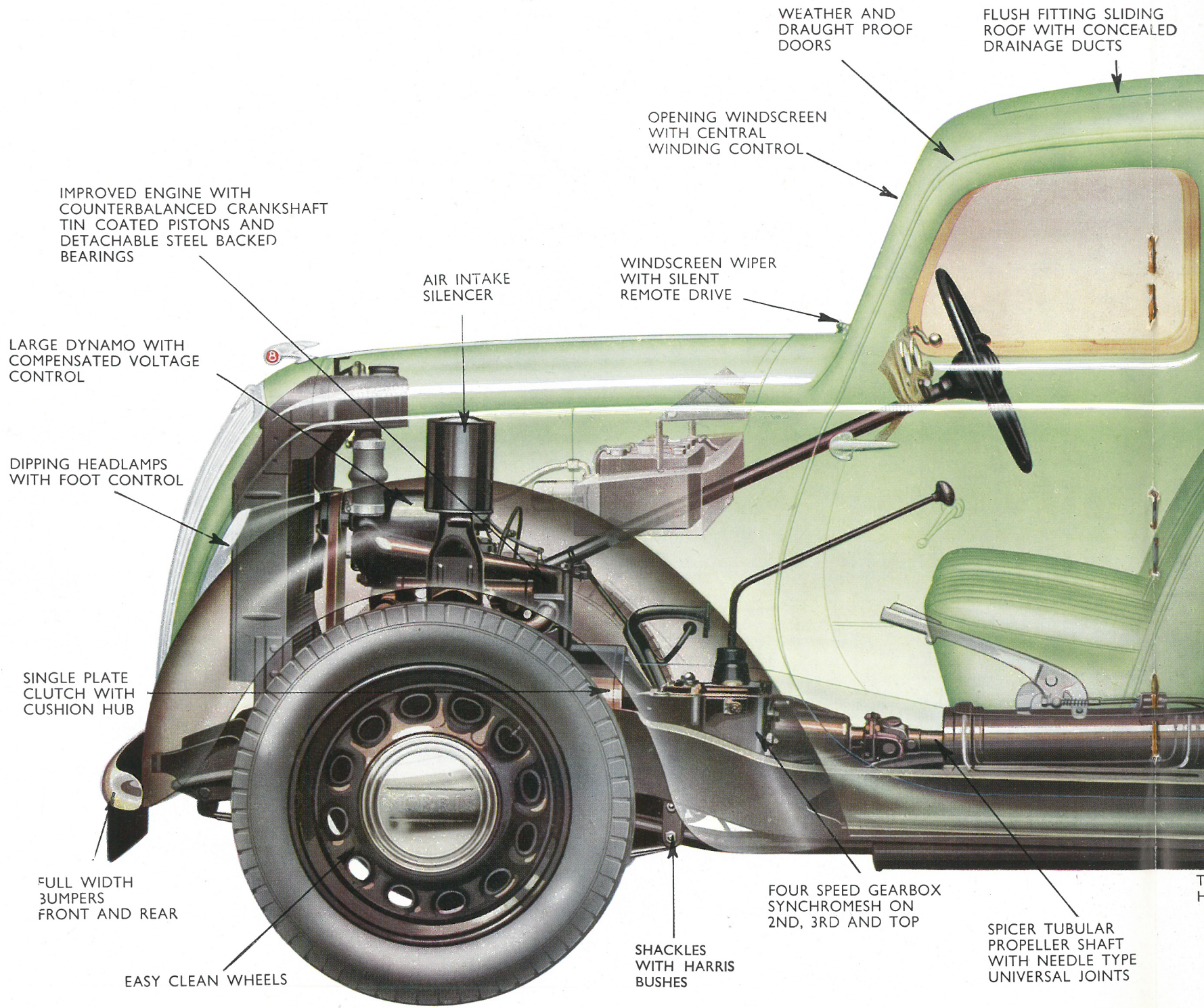

IMPROVED ENGINE WITH
COUNTERBALANCED CRANKSHAFT
TIN COATED PISTONS AND
DETACHABLE STEEL BACKED
BEARINGS

LARGE DYNAMO WITH
COMPENSATED VOLTAGE
CONTROL

DIPPING HEADLAMPS
WITH FOOT CONTROL

SINGLE PLATE
CLUTCH WITH
CUSHION HUB

FULL WIDTH
BUMPERS
FRONT AND REAR

EASY CLEAN WHEELS

AIR INTAKE
SILENCER

WINDSCREEN WIPER
WITH SILENT
REMOTE DRIVE

OPENING WINDSCREEN
WITH CENTRAL
WINDING CONTROL

WEATHER AND
DRAUGHT PROOF
DOORS

FLUSH FITTING SLIDING
ROOF WITH CONCEALED
DRAINAGE DUCTS

FOUR SPEED GEARBOX
SYNCHROMESH ON
2ND, 3RD AND TOP

SHACKLES
WITH HARRIS
BUSHES

SPICER TUBULAR
PROPELLER SHAFT
WITH NEEDLE TYPE
UNIVERSAL JOINTS

ED

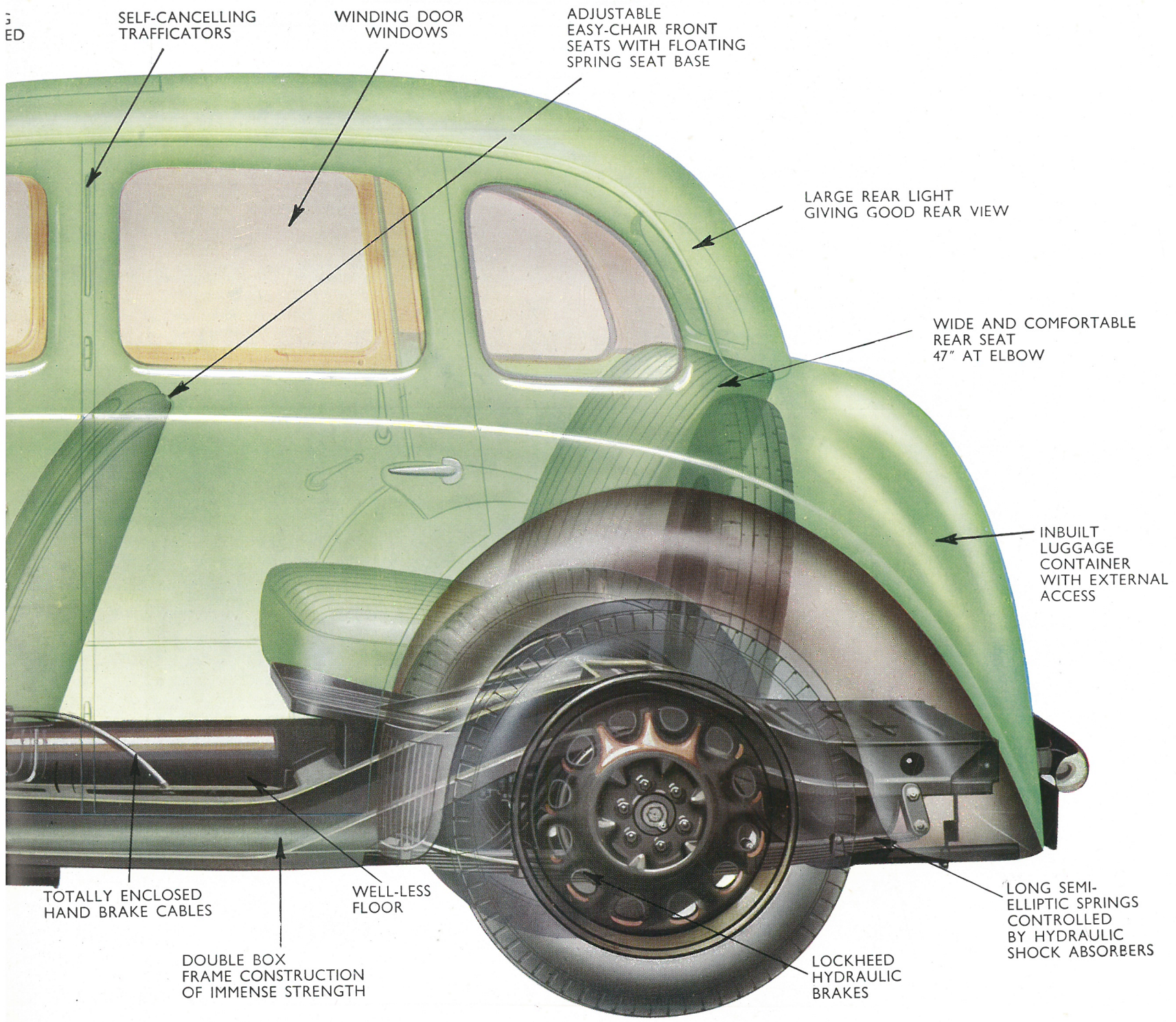

SELF-CANCELLING TRAFFICATORS

WINDING DOOR WINDOWS

ADJUSTABLE EASY-CHAIR FRONT SEATS WITH FLOATING SPRING SEAT BASE

LARGE REAR LIGHT GIVING GOOD REAR VIEW

WIDE AND COMFORTABLE REAR SEAT 47" AT ELBOW

INBUILT LUGGAGE CONTAINER WITH EXTERNAL ACCESS

TOTALLY ENCLOSED HAND BRAKE CABLES

WELL-LESS FLOOR

DOUBLE BOX FRAME CONSTRUCTION OF IMMENSE STRENGTH

LOCKHEED HYDRAULIC BRAKES

LONG SEMI-ELLIPTIC SPRINGS CONTROLLED BY HYDRAULIC SHOCK ABSORBERS

The

MORRIS EIGHT (SERIES "E") FOUR-DOOR SALOON

THE Morris Eight (Series "E") Four-Door Saloon is the economy car which the family man of moderate means has always been looking for. Fast, comfortable and safe, with interior accommodation equal to most Tens, it is capable of meeting the most exacting requirements.

Exceptional leg and head room is provided for four people, while the width of the new model is such that a rear seat 47 in. wide at elbow has been incorporated. Luggage accommodation—so important to the family man—has been well considered, and an inbuilt luggage container with external access is provided, having a capacity of nearly $5\frac{1}{2}$ cubic feet; enough for your week-end journeys.

The Morris Eight Four-door Saloon is obtainable in Black with Brown upholstery only until further notice. Both the fixed head saloon and the sliding head saloon are upholstered in leather.

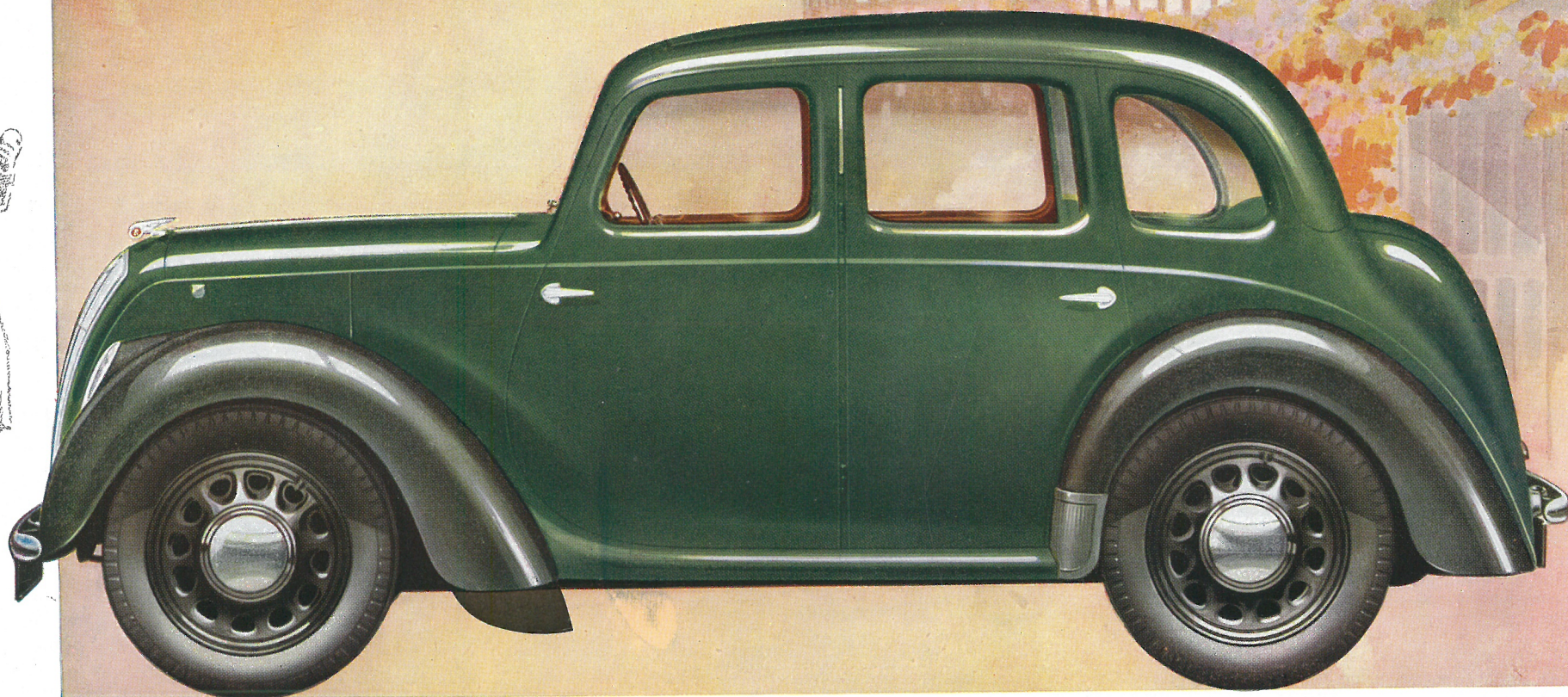

SEATING DIMENSIONS

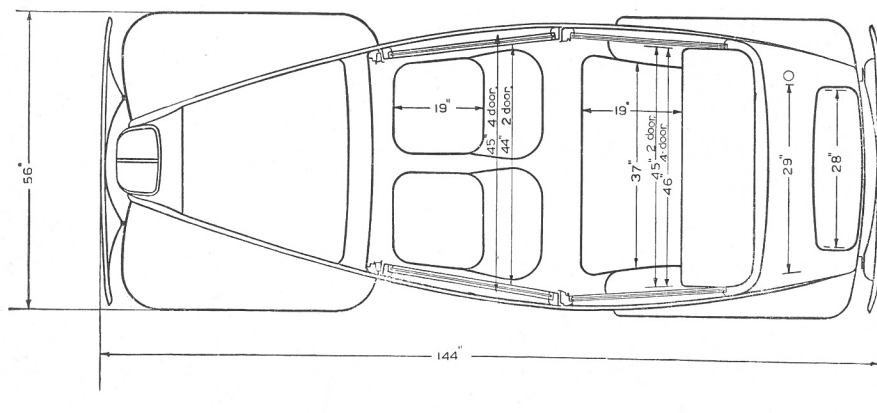
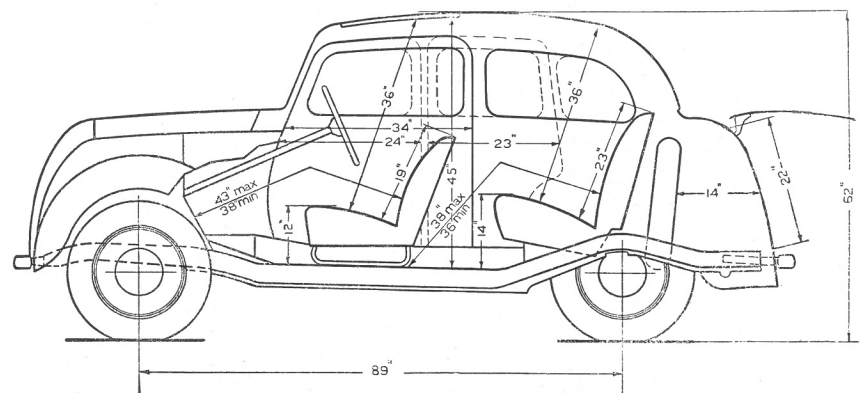

The Morris Eight (Series "E") is an exceptionally roomy car and provides considerably better accommodation than other cars in its class. A comparison of the interior dimensions indicated on the accompanying diagrams will indicate the truth of this statement.

SERVICE

MORRIS SERVICE is as thoroughly specialised as the car production. Nuffield Exports Limited retain their interest in their cars after they are sold and want to know that you are obtaining the utmost satisfaction and pleasure from their products. The vast Morris Dealer organisation is always at your service. During the early life of the car, soon after it has completed 500 miles, you are entitled to have it inspected, free of charge, by the Morris Dealer from whom you purchased it. This attention given during the critical period in the life of the car makes all the difference to its subsequent life and performance. This service includes:—

- (a) Drain sump, gearbox and back axle, and refill with one of the approved oils (see *Manual*).
- (b) Oil and grease vehicle throughout.
NOTE.—New lubricants chargeable to customers.
- (c) Check and, if necessary, adjust:—
 - (1) Ignition timing.
 - (2) Tappet clearances.
 - (3) Carburetter control gear, mixture setting and slow-running.
 - (4) Dynamo drive belt.
 - (5) Correct clearance for clutch pedal.
 - (6) Alignment of front wheels.
 - (7) All steering controls.
 - (8) Tyre pressures.
- (d) Adjust brakes and check level of Lockheed fluid in supply tank.
- (e) Look over and tighten all nuts, particularly cylinder head, wheels, spring clips and body bolts.
- (f) Top-up battery and check working of all electrical equipment.

All this first service is free, only material used being charged for.

The issue of this list does not constitute an offer. The right is reserved to alter specifications without notice.

GUARANTEE

1. For a period of SIX MONTHS from the date on which a new Morris Car or Chassis is delivered to the first owner-user thereof Nuffield Exports Limited will exchange or repair any part or parts thereof which needs or need replacement or repair by reason of defective workmanship or defective material.

The Company will not be responsible for any expense which the purchaser may incur in removing or having removed or in replacing or having replaced any part or parts to be sent for inspection or in fitting or having fitted any new parts supplied in lieu thereof.

2. No claim for exchange or repair can be considered hereunder unless the person claiming
 - (a) Immediately upon discovery of the alleged defect returns the part or parts complained of to the Company's authorised Distributor in the territory in which the Car or Chassis was purchased carriage paid.
 - (b) Sends therewith particulars of the chassis number and engine number of the Car or Chassis in question, as shown on the manufacturer's identification plate.
 - (c) Sends also full particulars of the claim and of the reasons therefor, stating in such particulars the date of the purchase and the name and address of the person or firm from whom the Car or Chassis was bought.
 - (d) Refers to this Guarantee.
3. This Guarantee shall not apply to
 - (a) Any accessories or proprietary fittings whatsoever.
 - (b) Any Car or Chassis used
 - (i) As a Hackney Carriage.
 - (ii) For hiring out.
 - (iii) For any purpose other than the private or genuine commercial use of the owner-user.
 - (c) Any defective part or parts which in the opinion of Nuffield Exports Limited has or have been injured by wear and tear or by any form whatsoever of improper use of or from any alteration whatsoever to the Car or Chassis.
 - (d) Any second-hand Car or part or parts thereof.
 - (e) Anything whatsoever not manufactured by Morris Motors Limited and sold by the Company.
 - (f) Any part or parts of a Chassis to which a body which in the opinion of the Company is unsuitable has been fitted.
 - (g) Any vehicle in or to which any part not manufactured or sold by Morris Motors Limited has been affixed.
4. The liability of Nuffield Exports Limited is limited to exchange or repair under Clause 1 hereof. Every form of liability for every form of consequential loss or damage is hereby expressly excluded.
5. This Guarantee is given in lieu of and excludes every condition or warranty, whether statutory or otherwise, whatsoever not herein expressly set out.

DATA

Bore	57 mm. (2.24 in.)
Stroke	90 mm. (3.54 in.)
Cubic capacity	918 c.c. (56.02 cu. in.)
Wheelbase	2.26 metres (89 in.)
Track (front)	1.14 metres (44 $\frac{5}{8}$ in.)
Track (rear)	1.175 metres (46 $\frac{1}{4}$ in.)
Tyre size	4.50—17
Wheel size..	2.5 × 17

Gear ratios :	1st	20.88 to 1
Synchronesh	2nd	12.158 to 1
	3rd	8.14 to 1
	4th	5.286 to 1
	Reverse	20.88 to 1

Sparking plugs 14 mm. Champion L.10

Petrol tank capacity 5 $\frac{1}{2}$ gallons

Overall length 12 ft. 0 in.

Overall width 4 ft. 8 in.

Overall height 5 ft. 2 in.

The issue of this list does not constitute an offer. The right is reserved to alter specifications without notice.

NUFFIELD EXPORTS LIMITED

VISCOUNT NUFFIELD, G.B.E. *Chairman* SIR MILES THOMAS, D.F.C. *Vice-Chairman* S. G. K. SMALLBONE *Managing Director*

COWLEY . . . OXFORD . . . ENGLAND

Telephone: OXFORD 77733

Telex: OXFORD TELEX 7168

Telegrams and Cables: MOREX, OXFORD

Codes: BENTLEY'S, BENTLEY'S SECOND PHRASE, A.B.C. (5TH AND 6TH EDITIONS), WESTERN UNION AND PRIVATE

FRONT