

AUSTIN



A 70 HAMPSHIRE

Specifications



2500

99

ENGINE: Bore 3.125 ins. (79.4 mm.); stroke 4.375 ins. (111.1 mm.); capacity 134.1 cu. in. (2,199 c.c.); b.h.p. 68 at 3,800 r.p.m.; max. torque 116 lbs. ft. at 1,700 r.p.m.; compression ratio 6.8 to 1.

Cylinders: Four cylinders cast integral with crankcase. Full length water jackets. Detachable cast iron head carrying overhead valve rocker gear and connections for the heater unit.

Crankshaft: Forged steel counterbalanced crankshaft supported by three detachable "Thinwall" bearings.

Connecting Rods: Forged steel with detachable "Thinwall" big-end bearings.

Pistons: Split skirt pistons in aluminium alloy with anodised finish. Two compression and one oil control ring fitted.

Camshaft: Forged steel supported by three "Thinwall" bearings. Cams of patented design for quiet operation. Drive by duplex roller chain from crankshaft with tensioner ring of synthetic rubber to ensure quiet chain operation.

Valves: Overhead valves operated by push-rods. Exhaust valves of heat- and corrosion-resisting steel. Inlet valves of silicon chrome alloy steel. Valve oil seals are fitted.

Lubrication: Pressure gear pump forces oil to all main, big-end, camshaft and overhead valve rocker-shaft bearings. Holes in the big-end bearings provide for jet lubrication of the cylinder walls and the front camshaft bearing provides a controlled feed of oil to the timing chain. Both main and big-end bearing oil feeds are of a patented design which ensures longer crankshaft life. A full-flow filter is fitted. Oil capacity 10 pints (5.6 litres), plus 2 pints (1.1 litres) for filter.

Cooling: Circulation by centrifugal type pump with thermostat control. Fan cooled patented radiator to prevent loss of cooling water through expansion. Water is directed to plug bosses and exhaust port walls. Cooling system capacity 20 pints (11.2 litres).

Ignition: Coil and battery ignition, with automatic advance and retard, and additional vacuum control.

Dynamo: 12-volt fan ventilated unit, with compensated voltage control.

Starter: Lucas unit operated with solenoid control.

Fuel System: Fuel from a rear tank of 12½ gallons (56 litres) capacity is fed by an AC mechanical pump to a Zenith down-draught carburettor with "L" type air cleaner. The aluminium alloy induction manifold incorporates a stainless steel hot spot. Oil bath filter available for export.

Mountings: Flexible inclined "live" rubber mountings, front and rear, with integral torque reaction stop at front, and adjustable locating unit at rear.

CLUTCH: A flexible dry single-plate Borg and Beck clutch is employed with a spring cushion drive. The clutch pedal is isolated from the clutch housing by a special adjustable linkage. Clutch diameter 8 ins. (20 cm.)

GEARBOX: The gearbox has four forward speeds and reverse. The gear lever is mounted on the steering column, and there is synchromesh engagement for second, third and top gears. The gearbox mainshaft is extended in a special housing which incorporates a screw type pump to deliver oil under pressure through the hollow mainshaft to the shaft bearings. Oil capacity 3 pints (1.68 litres).

The goods manufactured by the Austin Motor Company Limited, are supplied with an express Warranty which excludes all warranties, conditions and liabilities whatsoever implied by Common Law, Statute or otherwise. **PRICES.**—The Company reserves the right to vary the list prices at any time and all goods are invoiced at the prices current on day of delivery. **SPECIFICATION.**—The Company reserves the right on the sale of any vehicle to make before delivery without notice any alteration to or departure from the specification, design or equipment detailed in this publication.

The "A.70" Hampshire Saloon is available with fixed or sliding head as required.

THE AUSTIN MOTOR EXPORT CORPORATION LTD.

LONGBRIDGE · BIRMINGHAM

and

479-483 OXFORD STREET, LONDON, W.1, ENGLAND

1950

A NEW LEADER IN STYLE & PERFORMANCE

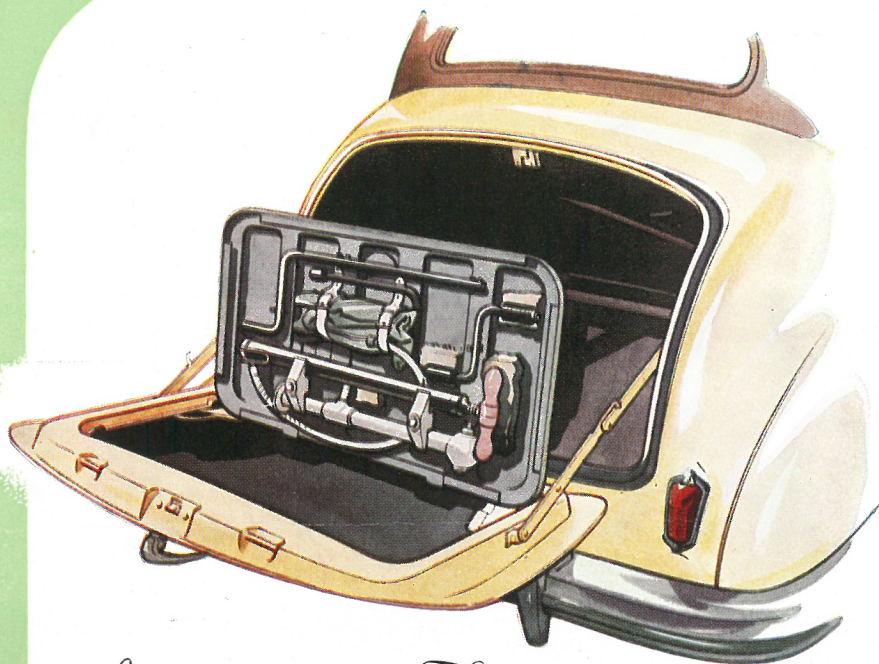

Luggage and Tools

There is plenty of room for luggage, and the rear panel which forms a platform for additional items, encloses a compact built-in tool tray.

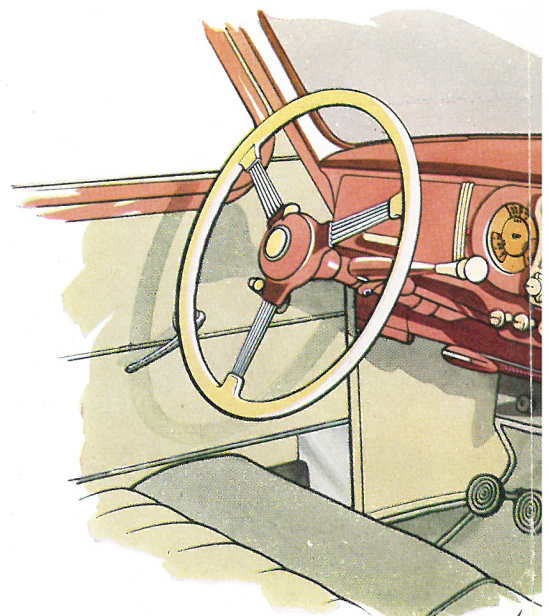

In

The center console is between the front seats, and contains the radio, and the screen.

Rear Elegance

The smooth rear lines are enhanced by a sturdy chromium wrap round bumper. Access to the rear wheels is gained by detachable fairings.

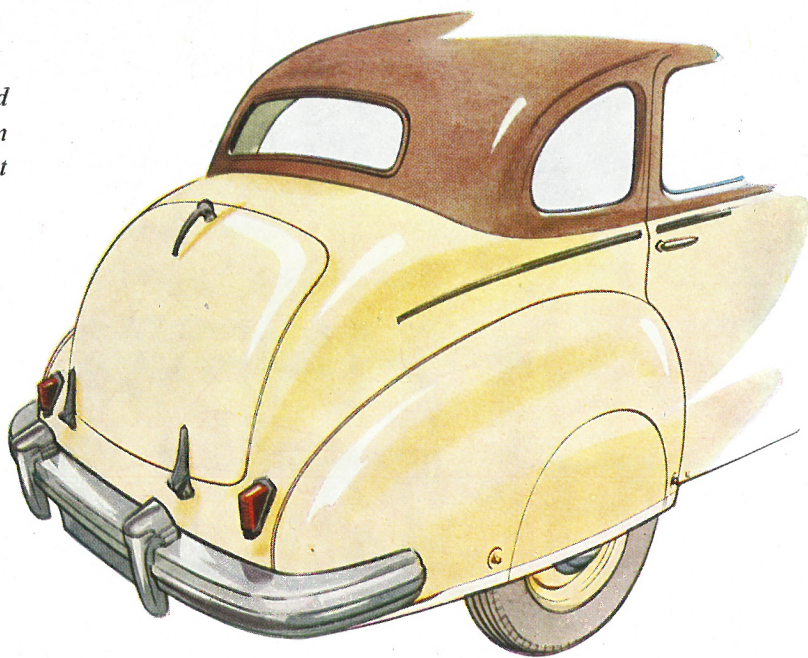

ANCE from

A U S T I N

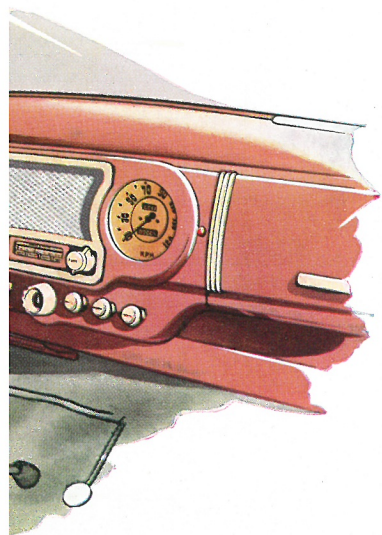

truments

mounted instruments
in two closed glove
compartments. The grille is for
a ventilating, heating
and demisting unit is fitted.

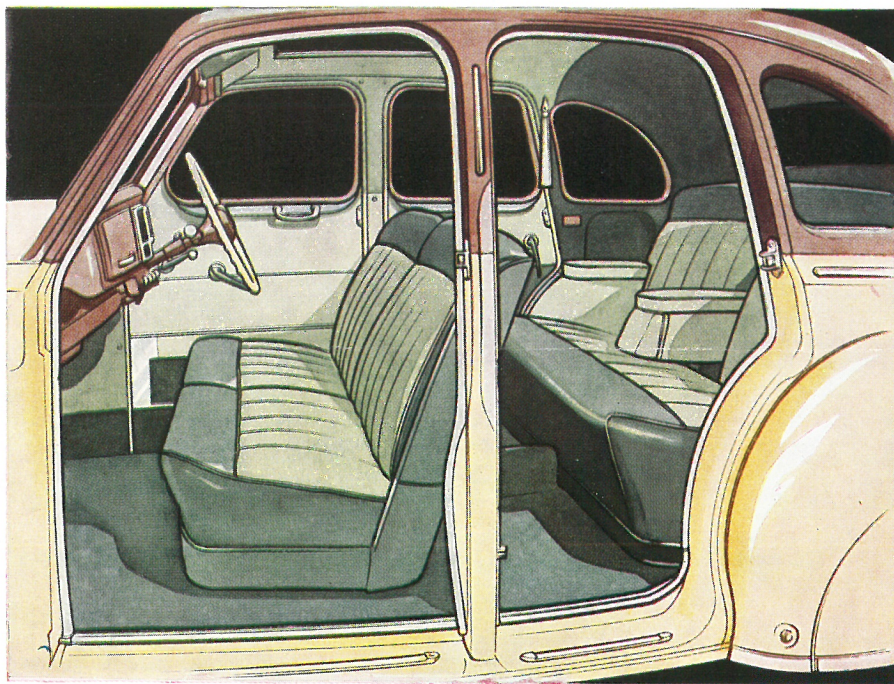

Interior Comfort

COACHWORK appointments in the Hampshire saloon will give special pleasure. The seating, upholstered in leather or leather and cloth, is wide, deep and comfortable and the adjustable front seats, though individual, are close mounted to give seating for three if required. Other most useful refinements are the very generous front door pockets, the sliding roof, dual sun visors and thick carpets. In every detail this is a car of taste and quality.

you can depend on it

A NEW LEADER IN STYLE & PERFORMANCE

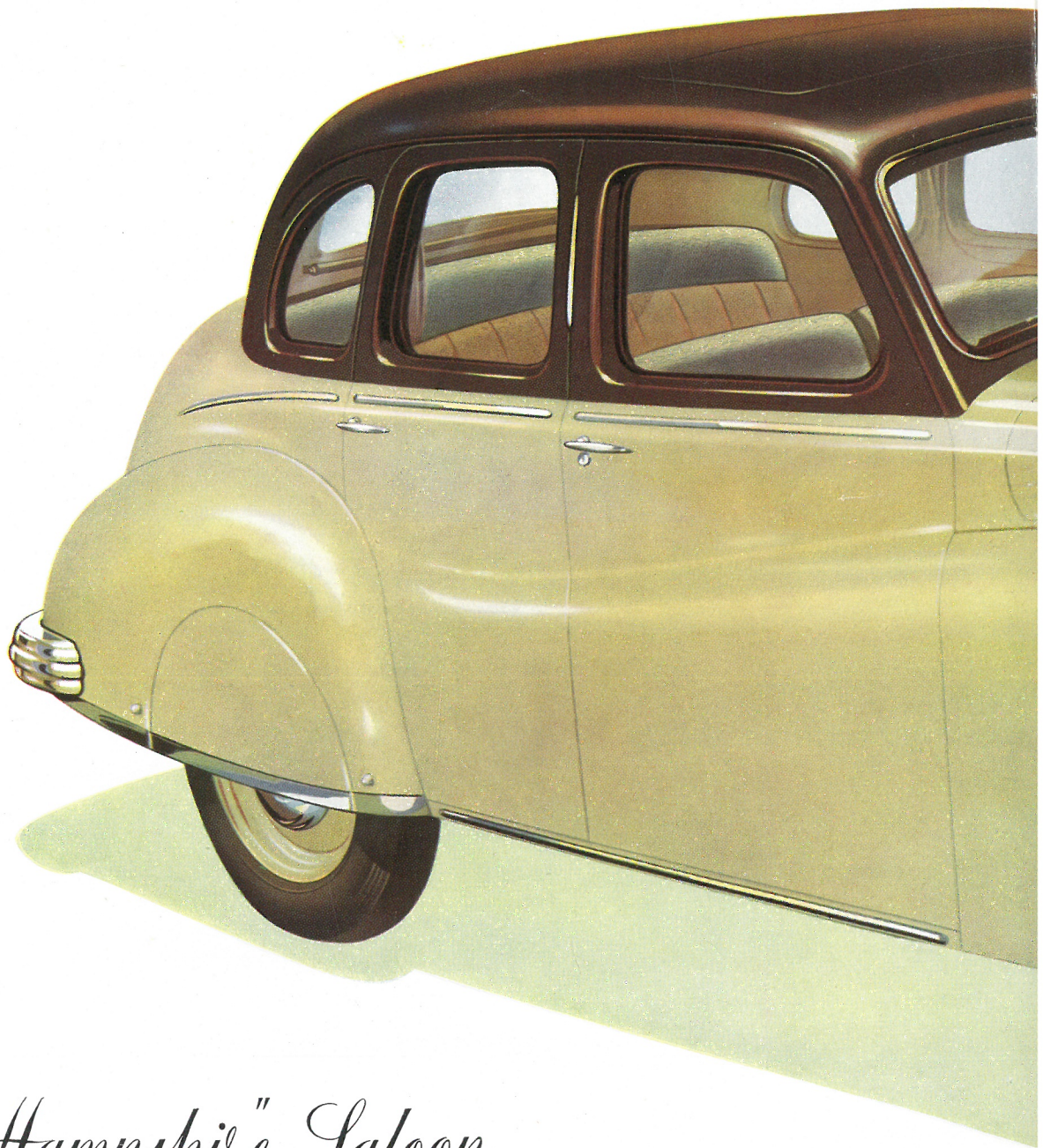

The "Hampshire" Saloon

*available with left or right
hand steering.*

ADVANCE from

A U S T I N



YOU'LL like this new Austin. You'll like it for its modern, compact and purposeful styling. You'll like to drive it for its refreshing acceleration, smooth suspension and complete ease of steering and control. Your passengers too will appreciate the quiet tasteful interior with its comfortable seating and excellent all-round visibility.

For this new Austin has many superb refinements that will appeal to every motorist—smooth four-cylinder overhead-valve engine developing 68 b.h.p.—steering column control for synchromesh gears—**independent front suspension—powerful two-leading shoe Girling hydraulic brakes at the front with Girling mechanical rear brakes, and pistol grip handbrake.**

W

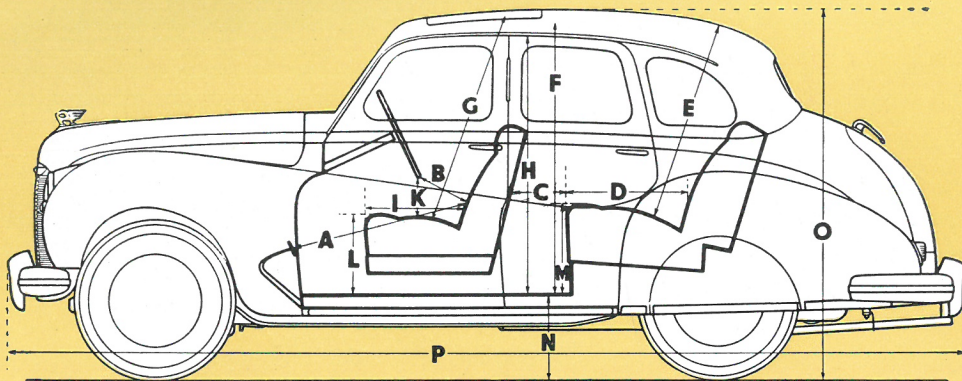

Dimensions

Pedal to Seat Squab—Max.	A	3'	3 $\frac{3}{4}$ "	1-01 m.
Min.		2'	8 $\frac{1}{2}$ "	0-82 m.
Steering Wheel to Seat Squab—Max.	B	1'	5 $\frac{1}{2}$ "	0-43 m.
Min.			10"	0-25 m.
Distance between Seats—Max.	C		11 $\frac{1}{2}$ "	0-29 m.
Rear Seat Cushion Depth	D	1'	8 $\frac{1}{2}$ "	0-52 m.
Height over Rear Seat	E	2'	10 $\frac{1}{2}$ "	0-87 m.
Maximum Interior Height	F	3'	10"	1-17 m.
Height over Front Seat	G	2'	11 $\frac{1}{2}$ "	0-90 m.
Maximum Height Door Opening	H	3'	7"	1-09 m.
Front Seat Cushion Depth	I	1'	6 $\frac{1}{2}$ "	0-47 m.
Front Seat Cushion Width		2'	0"	0-61 m.
Steering Wheel to Cushion	K		5 $\frac{1}{2}$ "	0-13 m.
Front Cushion above Floor	L	1'	2 $\frac{1}{2}$ "	0-35 m.
Rear Cushion above Floor	M	1'	3 $\frac{3}{4}$ "	0-36 m.
Minimum Height—Floor to Ground	N	5'	5"	0-40 m.
Overall Height	O		5'	1-65 m.
Overall Length	P	13'	7 $\frac{1}{2}$ "	4-15 m.
Overall Width		5'	6 $\frac{3}{8}$ "	1-69 m.
Scuttle Width		3'	9 $\frac{1}{4}$ "	1-15 m.
Body Width between Centre Pillars		4'	5 $\frac{1}{2}$ "	1-36 m.
Width between Rear Seat Arm Rests		3'	7 $\frac{1}{2}$ "	1-10 m.
Body Width between Rear Pillars		4'	4 $\frac{3}{4}$ "	1-33 m.
Rear Seat Maximum Width		4'	2 $\frac{1}{2}$ "	1-28 m.
Wheelbase		8'	0"	2-43 m.
Track (Front)		4'	5 $\frac{1}{2}$ "	1-35 m.
Track (Rear)		4'	7 $\frac{1}{2}$ "	1-40 m.
Ground Clearance			6 $\frac{1}{2}$ "	16-5 cm.
Turning Circle		39'	0"	11-88 m.
Luggage Compartment :				
Height of Opening		1'	4"	0-40 m.
Width of Opening		3'	0"	0-91 m.
Depth of Platform		2'	5"	0-73 m.
Capacity			9-5 cu. ft.	0-27 cu.m.
Carrier Load			1 cwt.	50 kgs.
Weight, less tools, spare wheel and fuel ...			25 cwt.	1270 kgs.

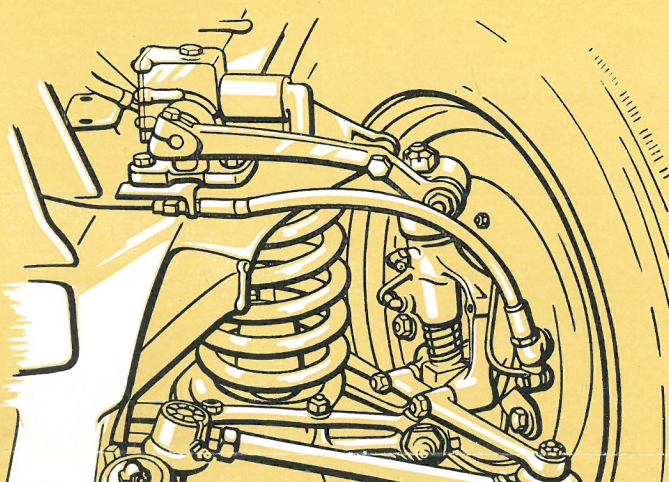

The independent front suspension is controlled by coil springs and double-acting hydraulic shock absorbers, ensuring full road stability, especially on corners, and smooth riding.



The "A70" Chassis

*sturdy, dependable, built
for a fine performance.*



and pistol grip handbrake.

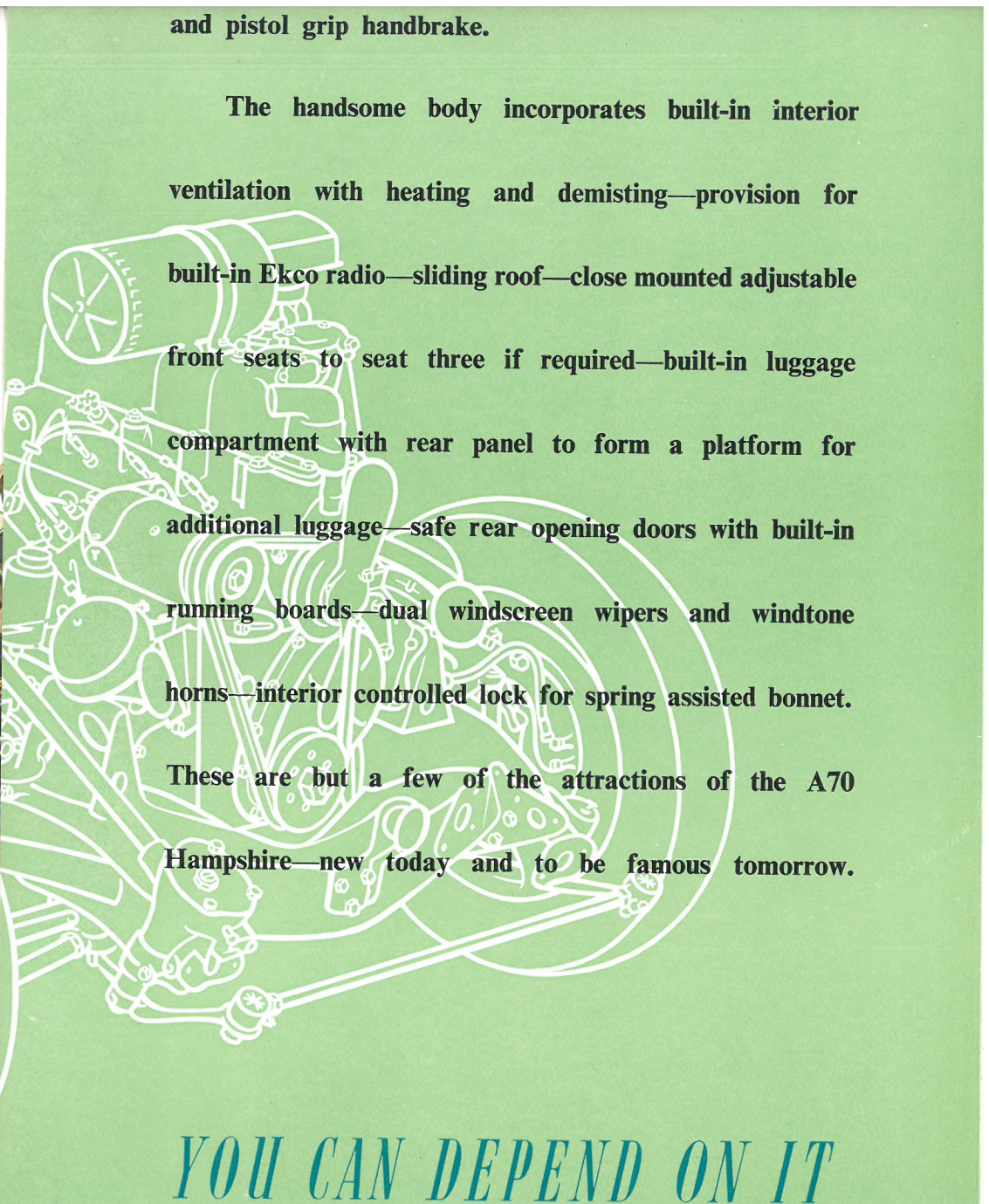

The handsome body incorporates built-in interior ventilation with heating and demisting—provision for built-in Ekco radio—sliding roof—close mounted adjustable front seats to seat three if required—built-in luggage compartment with rear panel to form a platform for additional luggage—safe rear opening doors with built-in running boards—dual windscreen wipers and windtone horns—interior controlled lock for spring assisted bonnet. These are but a few of the attractions of the A70 Hampshire—new today and to be famous tomorrow.

YOU CAN DEPEND ON IT

Giving an easy and positive gear change the steering column control allows unobstructed access to the driving seat from either side.

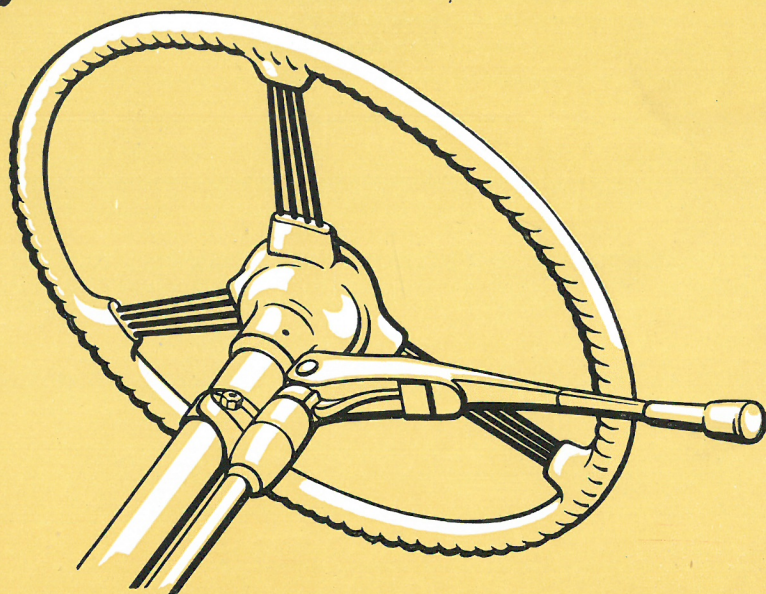

Colours

THE A70 Hampshire is available in attractive colours with interior furnishings to match. For the exterior, synthetic enamel is used to give a weatherproof finish of high and lasting lustre.

<i>COACHWORK</i>	<i>UPHOLSTERY</i>	<i>CARPETS</i>
<i>Black</i>	<i>Brown Leather</i>	<i>Brown</i>
<i>Elfin Green</i>	<i>Beige Leather</i>	<i>Fawn</i>
<i>Seal Grey</i>	<i>Grey Leather</i>	<i>Fawn</i>