

THE

*Austin*

TEN · TWELVE · FOURTEEN

1937  
~~~~~

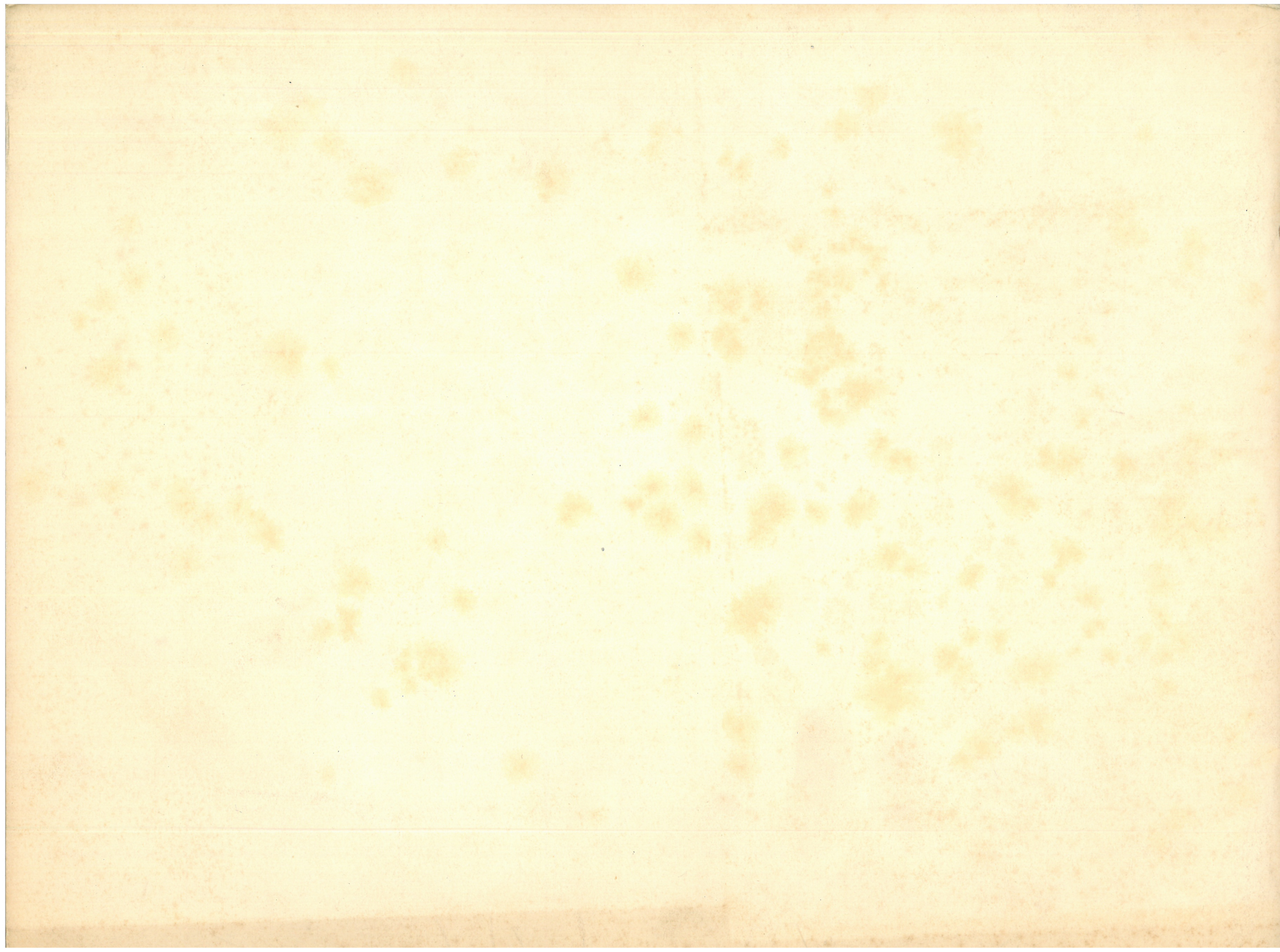

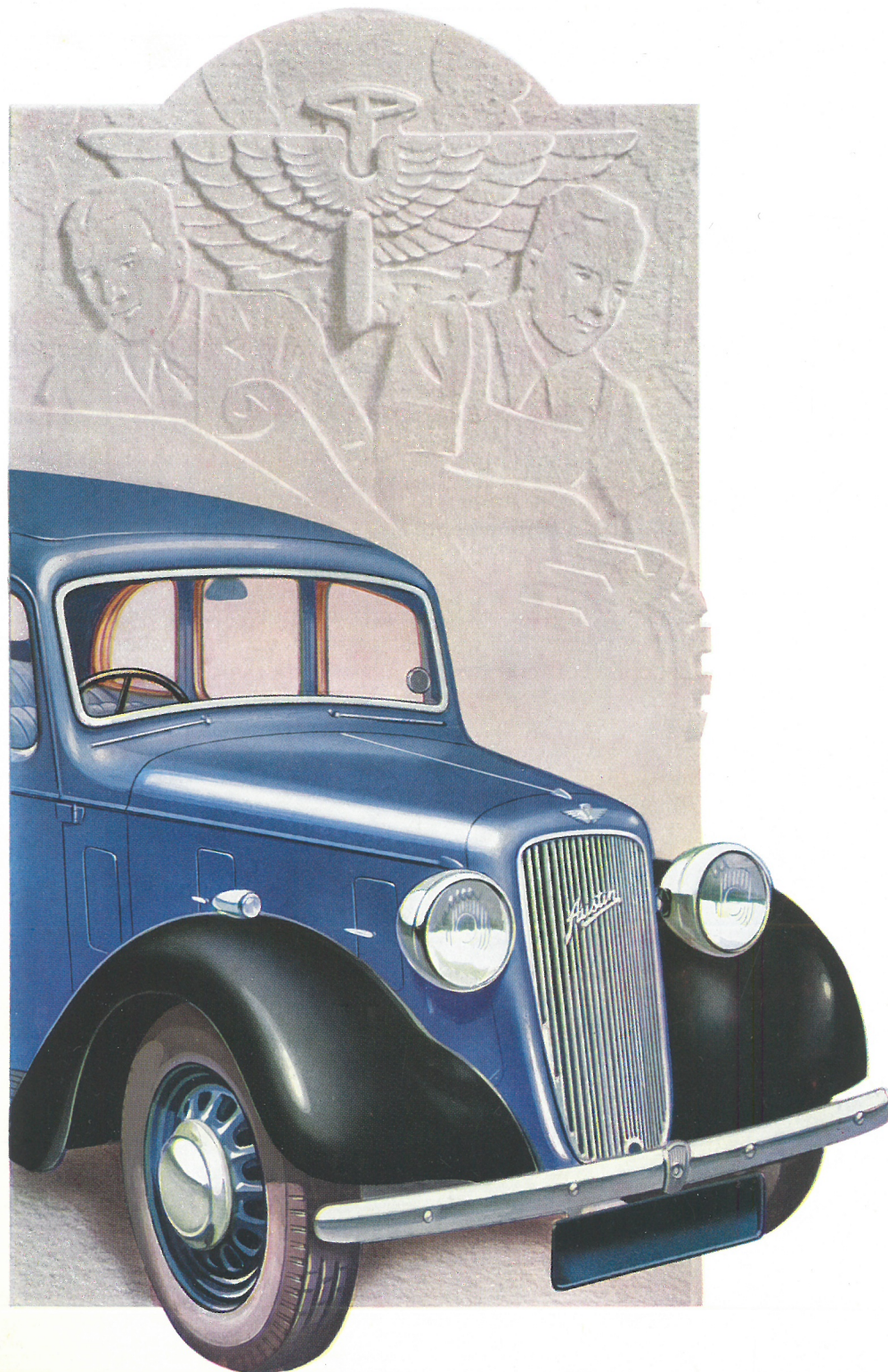

# *The* AUSTIN

## FOURTEEN, TWELVE & TEN

### *Modern & Dependable*

THE first Austin car was manufactured in Birmingham, England's greatest industrial centre, over thirty years ago, and to-day the Austin factory is Britain's largest self-contained motor works, employing nearly 20,000 people and having a production capacity of 3,000 cars a week.

Always renowned for their dependability, Austin cars in their latest form are handsome and modern without being extreme.

They are adequately powered to give good performance with economy and reliability. They combine high quality with comfort and safety, and the minimum expense or labour is required to maintain them in good order.

These attractive cars are entirely new in appearance and have improved all-round performance, but, in principle, they are similar to the popular models they replace. The **Goodwood** has a 15.9 R.A.C. rated six-cylinder engine developing over 38 horse-power; the **New Ascot** has the 11.9 four-cylinder power unit, which develops over 33 horse-power; and the **Cambridge** and **Conway** are powered by the "Ten-Four" engine developing 21 horse-power.

With their comprehensive equipment, the new Austins are the finest travel investment ever offered.

---

**THE AUSTIN MOTOR COMPANY LTD.**

LONGBRIDGE, BIRMINGHAM, ENGLAND

LONDON: 479-483, Oxford Street, W.1

# THE NEW SILENT

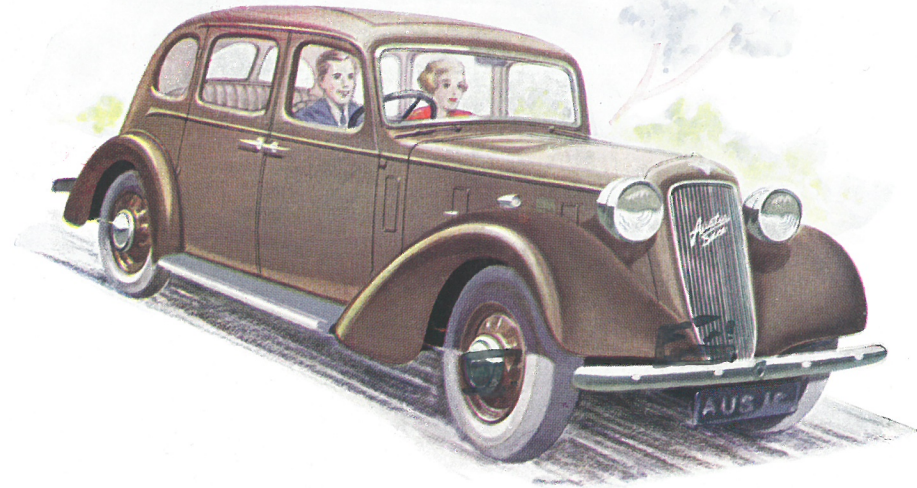

*Easy Riding at Speed.*

A NEW STANDARD OF TRAVEL is introduced with the Austin all-steel safety saloons, the **Goodwood**, the **New Ascot** and the **Cambridge**, and the **Conway** four-door cabriolet.

Austin dependability and economy are combined with greater safety, silent running and increased comfort.

## Quality Comfort.

Every possible care has been taken to promote the comfort of the driver and passengers. Upholstery is of high quality, with wide, deep and well sprung seats. The front seats are independently adjustable.

Luxurious pile carpets with thick felt underlays, door pockets, interior lights, ash trays, an artistic fascia board with large dial instruments, and other furnishings give the interior an atmosphere of comfort and ease and there is ample room for both driver and passengers.

Wide doors, besides giving easy access and exit, have deep windows to afford full vision. These, with the spacious windscreen and a large divided rear window, make the interior light and airy and are also an important aid to safe driving.

Riding comfort is assured by the adoption of Extra Low Pressure tyres, extra long and supple springs with hydraulic control, and inter-axle seating.

To minimise vibration, the engine, gearbox unit and the exhaust system are mounted on absorbent rubber.

## Silence Assured.

Every panel of the new saloons is insulated with special air cell lining for the elimination of resonance—floors, doors, scuttle, rear panels, sides and roof panels are all lined with absorbent material.

The gearbox opening in the floor is rubber sealed and the batteries, which are under the front seats, are isolated by steel pressings.

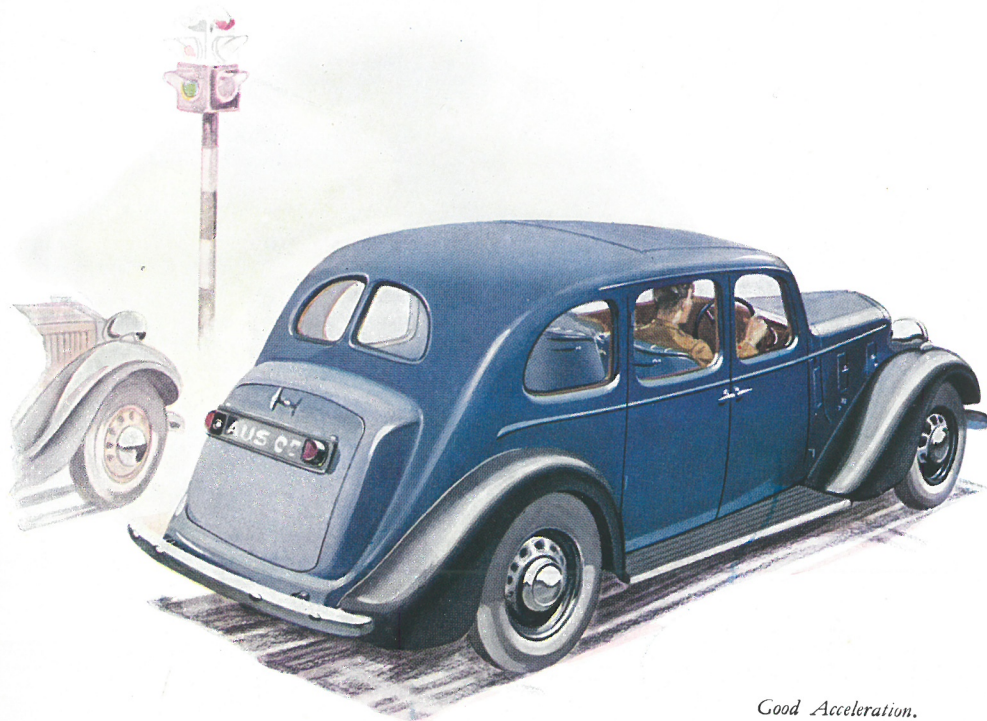

*Good Acceleration.*

# GLIDE AUSTINS

Under the pile carpets are thick rubberised felt underlays as well as insulating material and the doors have rubber draught excluders. Engine and road noises, heat and cold are kept out.

Air roar at speed is absent owing to the smooth flowing lines of the bodywork, the slope of the windscreen and the flush-fitting sliding roof. A new standard of silence, hitherto considered impossible, has been achieved by Austin engineers. One rides along the highways in quietness, ease and comfort.

## Safety Features.

With the Extra Low Pressure tyres and the all-steel roof, the new Austins incorporate many important safety features.

More traffic, faster roads and more engine power, demand better brakes. The new Austins have the safe and well tried Girling wedge-and-roller system, mechanical and light in operation, very powerful but smooth and progressive. A notable feature is automatic compensation between the front and rear brakes, whereby greater pressure is applied to the front brakes as weight is transferred to the front axle on retardation. Any tendency to skid is thereby avoided.

Wide track and long wheelbase make for stability and the long soft-riding springs are controlled by double acting hydraulic shock absorbers.

The frames have full length, deep side members welded to the X cross members to form a complete unit, light but of immense strength.

Triplex toughened glass is fitted to the windscreen and all side and rear windows (except cabriolet rear windows).

The sliding roofs are flush fitting and disappearing.

## Invest Now.

No other car combines Austin dependability, comfort, silence, safety, and economy for miles and miles of care-free travel.

Invest now and ride in a silent-glide Austin.

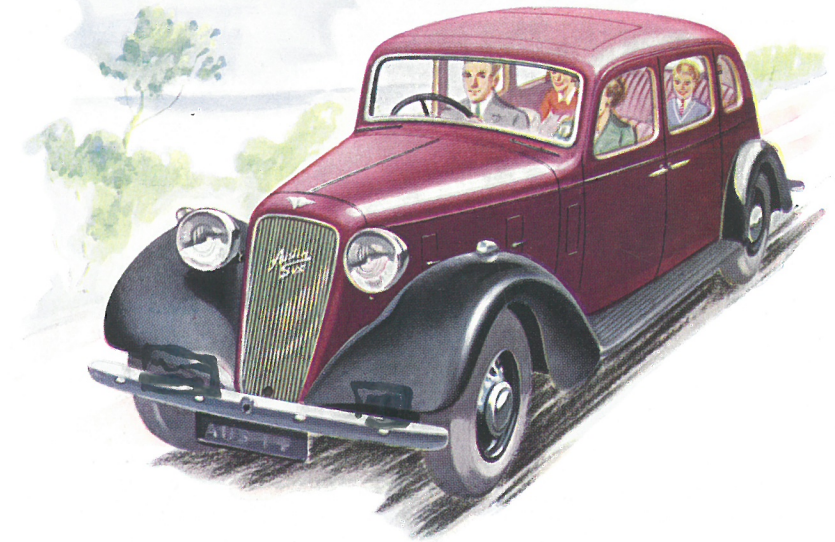

*Powerful Girling Brakes.*

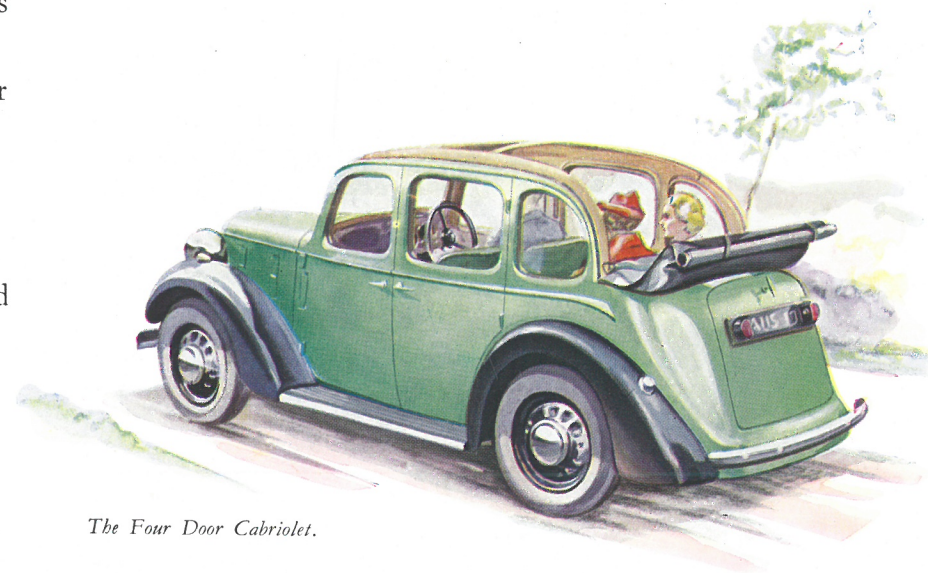

*The Four Door Cabriolet.*

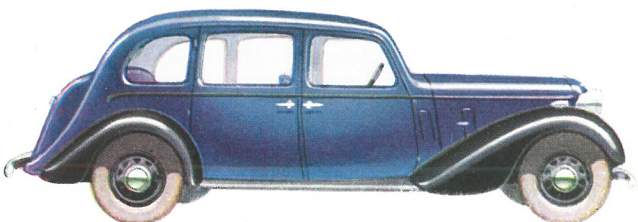
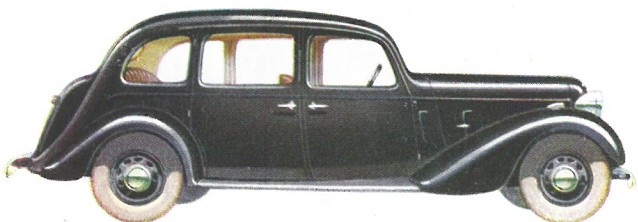
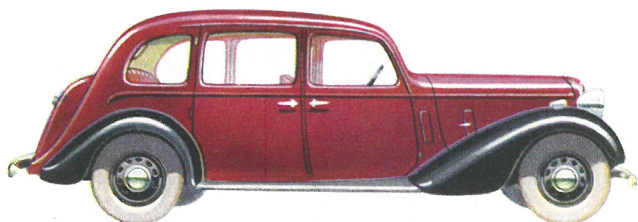
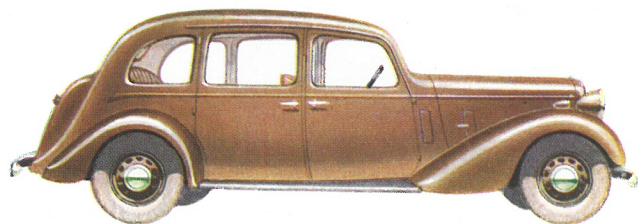
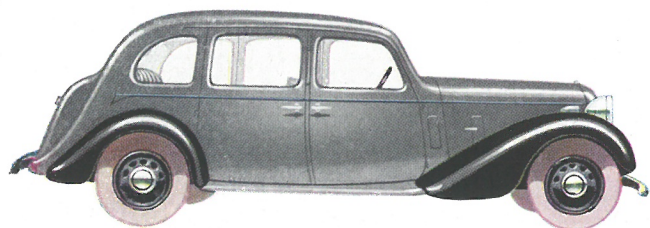

**T**HE **Austin Goodwood** saloon, with its smooth and powerful six-cylinder engine, is acclaimed by all to be on top of the market as the finest investment value in medium size cars. Its graceful, sweeping lines and handsome proportions were greeted with widespread enthusiasm immediately on announcement and the demand has far exceeded expectations.

From bumper to bumper the **Goodwood** is a beautiful car in exterior appearance. It has a handsome sloping radiator grille, wide and deep wings and upswept scuttle. The flush-fitting steel roof flows in unbroken curves to the divided rear window and the spacious luggage compartment.

Modern and distinctive, the symmetry of the outline, however, has not cramped interior accommodation and comfort. The seats are wide and deep, there is plenty of leg and elbow room and the windows are large to afford the maximum visibility in all directions for both driver and passengers.

Upholstery is in best selected hide or best quality leather and equipment is complete in every detail. Luxurious pile carpets are provided, with rubberised felt underlays, and the steering wheel is instantly adjustable over a range of three inches to suit the convenience of the driver. The front seats are independently adjustable.

Hidden under the floor carpets and felts, behind the seat cushions and above the head linings there is a special insulation material to absorb vibration, deaden drumming and generally make for silence. Every part of the all-steel body is insulated and, with air-roar eliminated by the smooth lines of the body, the **Goodwood** is a remarkably quiet car in which to ride.

There is enclosed and external luggage accommodation and, except on the lower price model, a spacious fitted luggage trunk, with straps, is provided.

The **Goodwood** has the greatest possible comfort, adequate performance, maximum safety and all that makes for Austin Dependability.

On subsequent pages is described the **New Ascot** saloon, which is similar to the **Goodwood** and has a four-cylinder engine.

*Colours available are: Royal Blue, Westminster Green, Maroon, Black, Pueblo Brown, Ash Grey.*



*The Austin GOODWOOD Fourteen Saloon*

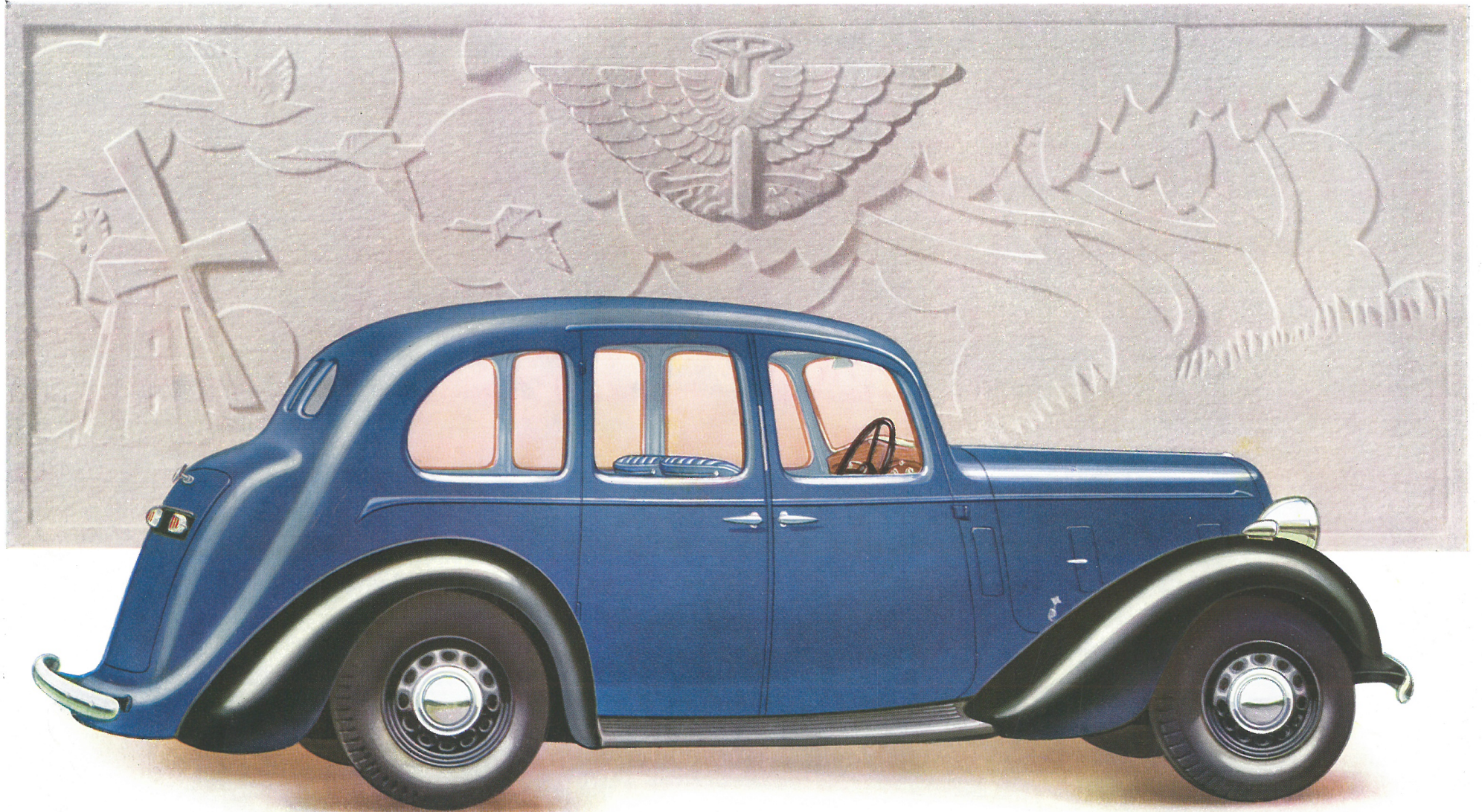

*The Austin* NEW ASCOT *Twelve Saloon*



**T**HE **New Ascot** saloon is similar in design and equipment to the **Goodwood** and is mounted on a chassis of slightly shorter wheelbase with a four-cylinder engine of 11.9 R.A.C. rating, giving increased fuel economy and carrying slightly lower English tax. The power unit and exhaust system are mounted on live rubber to insulate vibration from the chassis and body.

It is an all-steel saloon of generous proportions and most pleasing lines and is available with a flush-fitting and disappearing sliding-roof or a fixed-head, with or without a ventilator, as desired.

Graceful as it is, the **New Ascot** is extremely practical, with generous accommodation for passengers and luggage. The extra wide doors afford easy entrance and exit, and the deep windscreen and windows, all of Triplex toughened glass, assure excellent visibility. The deeply cushioned and softly sprung rear seat is forward of the axle for the greater comfort of the rear passengers.

Twin windscreen wipers operating from the scuttle, arm and foot rests for the rear passengers, a large cubby hole, an interior light with two switches, adjustable front seats, thick pile carpets, with rubberised felt underlays, and ash trays are some of the desirable refinements included in the specification.

The instruments are neatly grouped in two large and easily read dials and both enclosed and exterior luggage accommodation is provided, with a large trunk for certain models. Luggage straps are provided.

A choice of smart colour schemes is available in durable cellulose, with upholstery in best selected hide or best quality leather.

The **New Ascot** is a commodious family car with an economical engine and it will give many miles of comfortable, safe and care-free travel at very reasonable cost.

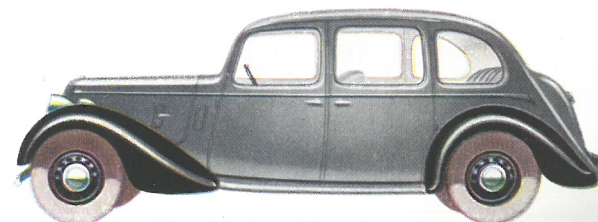
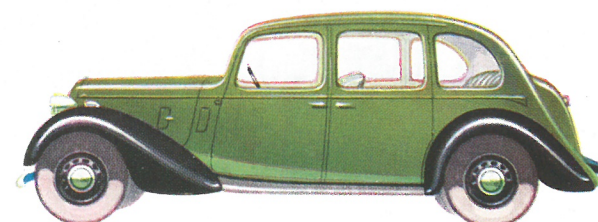
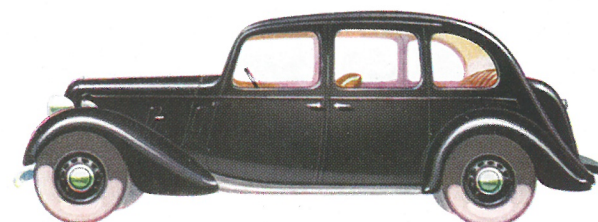
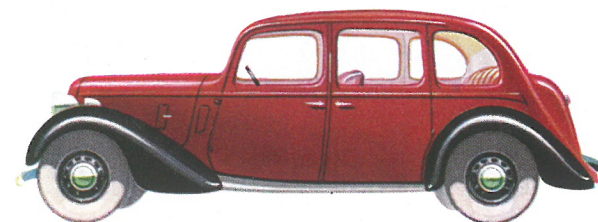
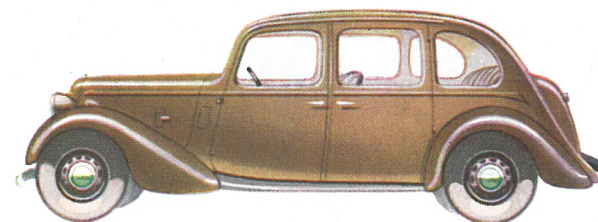

*Colours available are: Royal Blue, Westminster Green, Maroon, Black, Pueblo Brown, Ash Grey.*

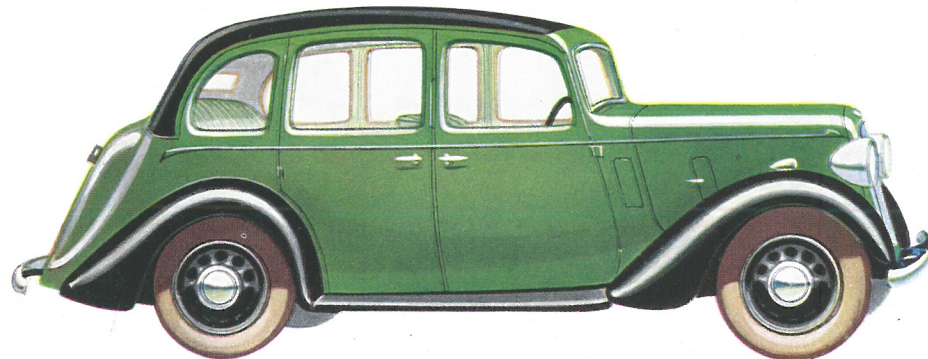
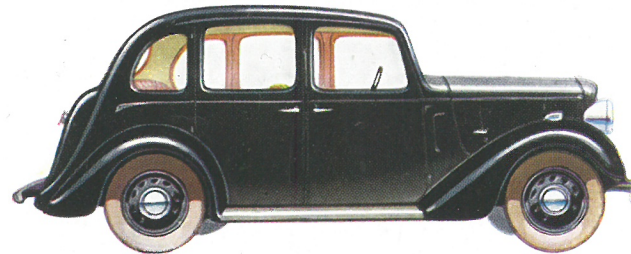
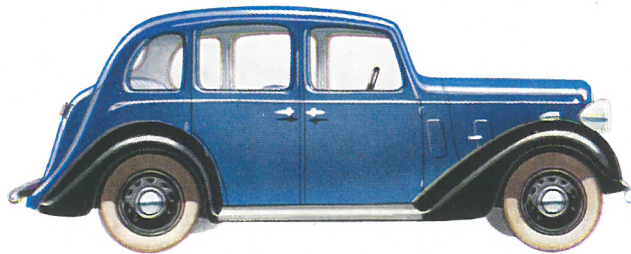
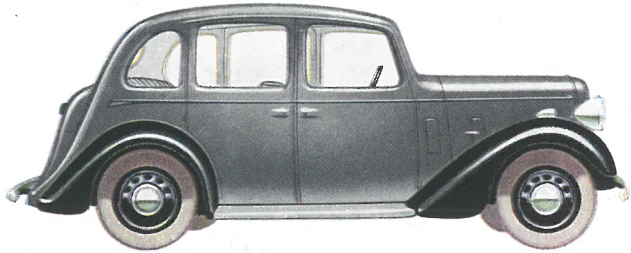
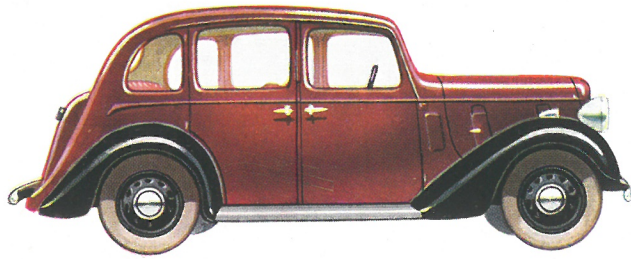

**T**HE **Cambridge** is a handy and most economical saloon, a full four-seater with attractive and graceful lines. It has Extra Low Pressure tyres and easy clean pressed steel spoke wheels.

Powered with the popular "Ten" engine, the performance is good, both in traffic and on the open road, and with its all-steel body, Triplex toughened glass and Girling brakes, the **Cambridge** is safe and dependable.

Forward engine mounting has made more space available for a larger body and the rear seat has been moved to a more comfortable position in front of the axle.

Two windscreen wipers operate from the scuttle, the front seats are independently adjustable and the steering wheel has an extra low and very comfortable rake. Roof light, concealed panel lights and remote control to the rear blind are provided and all doors have glove pockets and locks.

Draught and heat excluders are fitted to the pedals and the doors and the steel floors are sealed to minimise noise. Special anti-noise insulation is used to line all panels and in addition the thick pile carpets have rubberised felt underlays.

This new **Cambridge** is amazing investment value for the small family of limited means, and its remarkable economy of operation—low tax, petrol, oil, tyres and general maintenance costs—are unsurpassed.

**A**NOTHER NEWCOMER to the Austin range is the smart four-seater four-door **Conway** Cabriolet, on the same chassis as the **Cambridge** and very similar in dimensions and general line. The weatherproof hood rolls back to the half-open position or it can be fully lowered. Its operation is quite simple.

*Colours available are: Royal Blue, Westminister Green,  
†Maroon, Black, Pueblo Brown, Ash Grey.  
†Not on Cabriolet, which is also available in  
Cherry Red.*

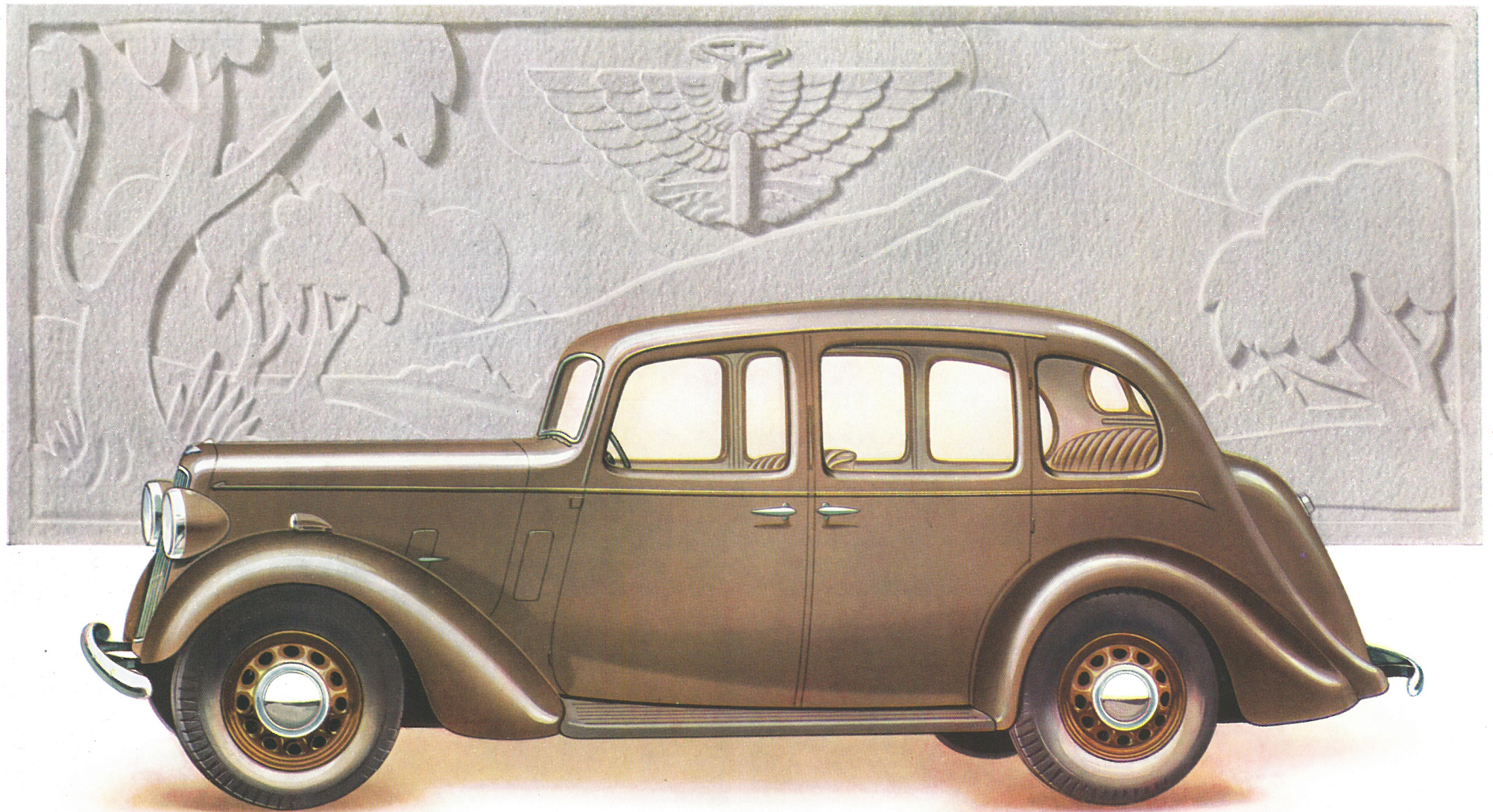

*The Austin* CAMBRIDGE *Ten Saloon*

# FURNISHINGS



*Wide Doors for Easy Access.*

## COLOUR SCHEMES.

### GOODWOOD AND NEW ASCOT.

| BODYWORK.          | UPHOLSTERY.                               | WINGS.       |
|--------------------|-------------------------------------------|--------------|
| Royal Blue.        | Blue.                                     | Black.       |
| Maroon.            | Maroon.                                   | Black.       |
| Westminster Green. | Green.                                    | Black.       |
| Pueblo Brown.      | Fawn.                                     | Malay Brown. |
| Ash Grey.          | Grey.                                     | Black.       |
| Black.             | { Grey, Brown,<br>Maroon, Fawn,<br>Green. | Black.       |

Sliding roof saloons are upholstered in best selected hide, and Fixed Head Saloons have seats and squabs in best quality leather, with leather cloth trimmings.

Pueblo brown saloons have lamps in Malay brown with chromium plated rims.

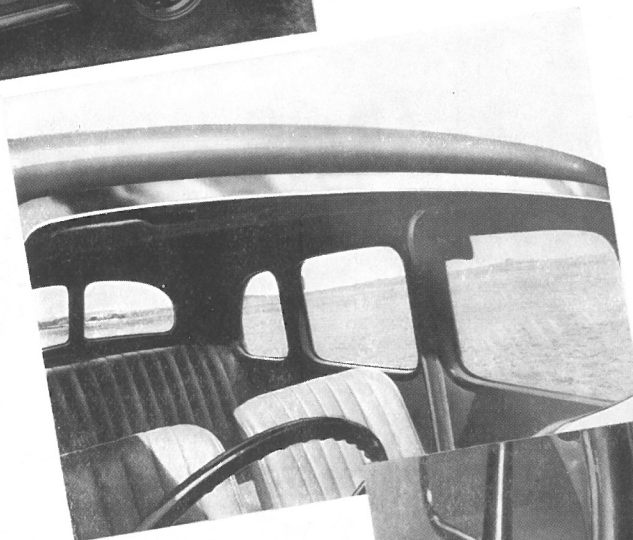

*Good Visibility All Round.*

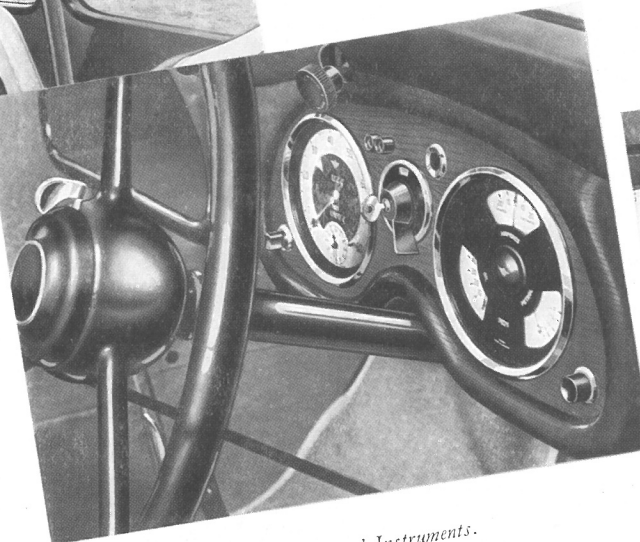

*Neatly Grouped Instruments.*

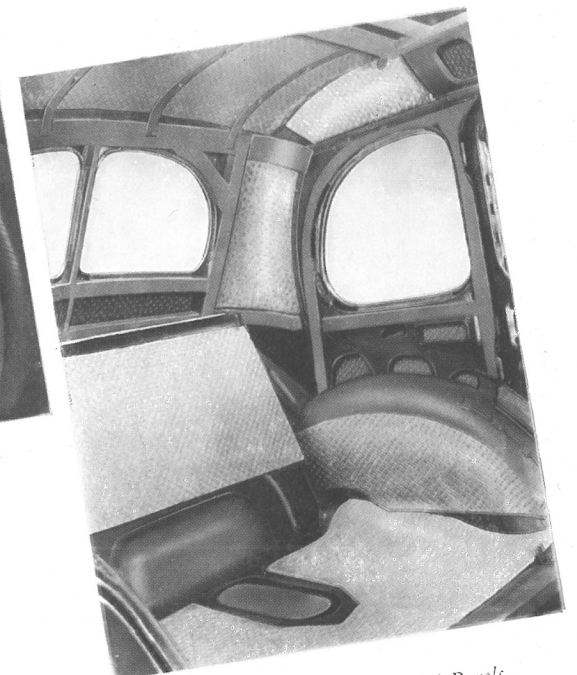

*Sound Insulation on All Panels.*

**G**OODWOOD and New Ascot upholstery is in \*best selected hide. Head and side lamps, windscreen frame and all fittings are chromium plated. The instruments, with indirect lighting, are grouped in two neat dials, one containing the needle-type trip speedometer and eight-day clock and the other the oil and fuel gauges and ammeter.

A large cubby hole is next to the instrument panel and the equipment includes self-cancelling direction indicators, side and \*centre arm rests and foot rests for the rear passengers, two \*sun visors, dual electric windscreen wipers operating from the scuttle, driving mirror, roof lamp with two switches, ash trays, remote control rear blind, \*quarter light blinds, \*parcel net in the roof, \*rope pulls, electric horn, foot operated dip-and-switch control, clutch and brake pedal rubbers, draught and fume excluders, bonnet and scuttle ventilators, door pockets, door locks, pile carpets and felt underlays.

Triplex toughened glass is fitted to the windscreen, side and rear windows. There is an enclosed\* luggage trunk and exterior luggage accommodation, with straps.

\*Fixed Head Saloons have seats and squabs upholstered in best quality leather and are without these items marked with an asterisk (\*).

# & EQUIPMENT

**C**AMBRIDGE and **Conway** upholstery is in \*best quality leather. Lamps and fittings are chromium plated and the instrument panel has two large dials, with indirect lighting.

Equipment includes needle-type trip speedometer, eight-day clock, oil and fuel gauges, ammeter, parcels compartment, self-cancelling direction indicators, driving mirror, concealed instrument lights, electric horn, side arm rests, two \*sun visors, dual electric windscreen wipers operating from the scuttle, roof lamp, ash tray, remote control rear blind, \*rope pulls, foot-operated dip-and-switch headlamp control, clutch and brake pedal rubbers, draught and fume excluders, bonnet and scuttle ventilators, door pockets, door locks, pile carpets and felt underlays.

Triplex toughened glass is fitted to windscreen, side and rear windows and there is enclosed luggage accommodation, with straps. A trunk is fitted at small extra cost.

The **Conway** cabriolet is finished in similar colours and has the same equipment as the **Cambridge** saloon, but is without roof light. The windscreen and side windows have Triplex toughened glass. Straps secure the hood in the semi-open or open positions.

\*Fixed Head Saloons have seats and squabs upholstered in best quality leather and are without those items marked with an asterisk (\*).



*Independent Screen Wipers.*



*Ample Luggage Accommodation.*

## COLOUR SCHEMES.

### CAMBRIDGE AND CONWAY.

| BODYWORK.          | UPHOLSTERY.                               | WINGS.       |
|--------------------|-------------------------------------------|--------------|
| Royal Blue.        | Blue.                                     | Black.       |
| † Maroon.          | Maroon.                                   | Black.       |
| Westminster Green. | Green.                                    | Black.       |
| Pueblo Brown.      | Fawn.                                     | Malay Brown. |
| Ash Grey.          | Grey.                                     | Black.       |
| Black.             | { Grey, Brown,<br>Maroon, Green,<br>Fawn. | Black.       |
| †† Cherry Red.     | Fawn.                                     | Black.       |

† Not Conway. †† Conway only.

Sliding roof saloons are upholstered in best quality leather, and Fixed Head Saloons have seats and squabs in best quality leather, with leather cloth trimmings.

Pueblo brown saloons have lamps in Malay brown with chromium plated rims.

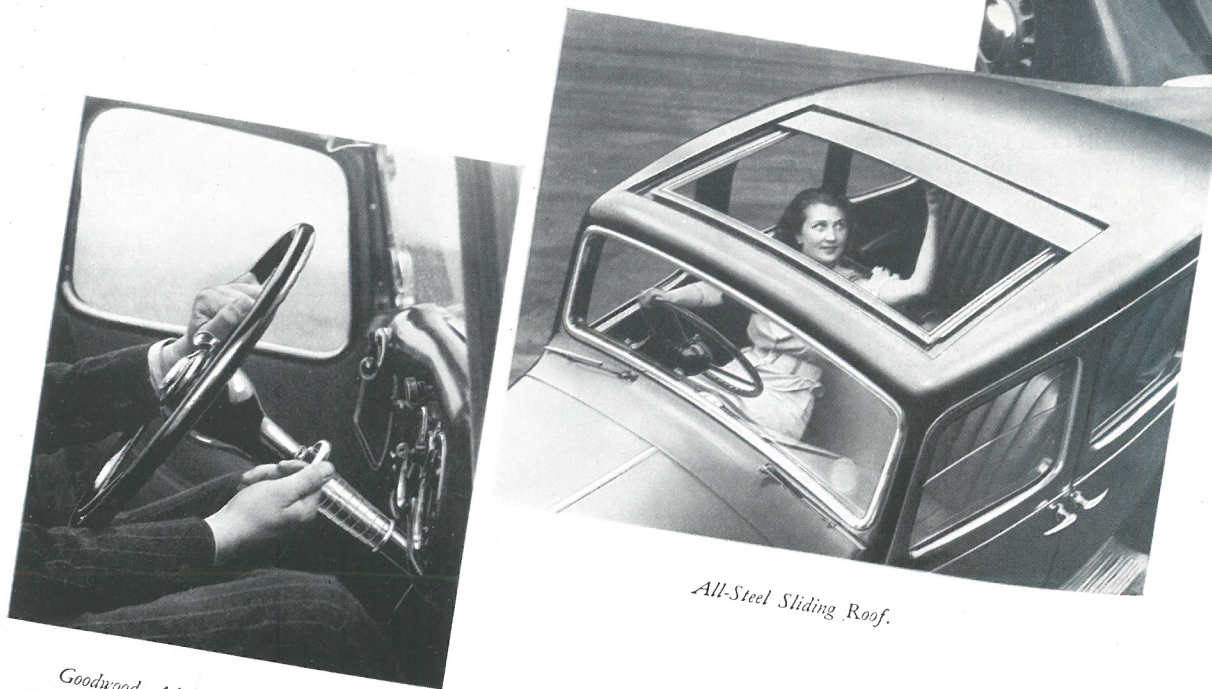

*All-Steel Sliding Roof.*

*Goodwood Adjustable Steering.*

# ENGINE & CHASSIS

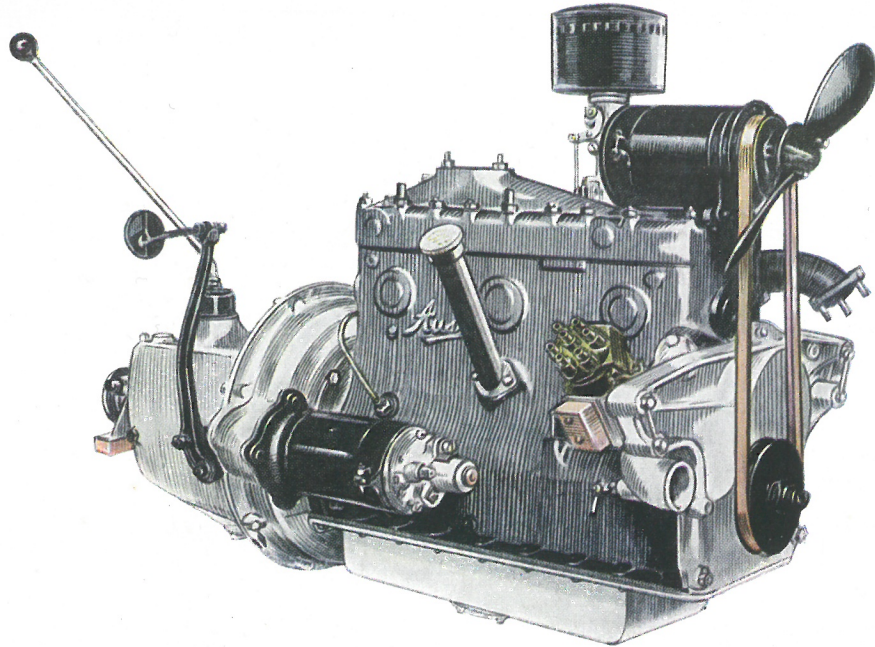

*The Goodwood Six-cylinder Engine.*

## Power Units.

|                         | GOODWOOD<br>FOURTEEN              | NEW ASCOT<br>TWELVE              | CAMBRIDGE AND<br>CONWAY TEN     |
|-------------------------|-----------------------------------|----------------------------------|---------------------------------|
| Cylinders ... ..        | 6                                 | 4                                | 4                               |
| Bore ... ..             | 2.58 ins.<br>65.5 mm.             | 2.73 ins.<br>69.35 mm.           | 2.4995 ins.<br>63.5 mm.         |
| Stroke ... ..           | 3.335 ins.<br>84.63 mm.           | 4 ins.<br>101.6 mm.              | 3.5 ins.<br>89 mm.              |
| Capacity ... ..         | 1,711 c.c.                        | 1,535 c.c.                       | 1,125 c.c.                      |
| Main Bearings ...       | 4                                 | 3                                | 3                               |
| B.H.P. ... ..           | 38.7 at 3,800 r.p.m.              | 33.7 at 3,600 r.p.m.             | 21.1 at 3,400 r.p.m.            |
| R.A.C. Rating ...       | 15.96                             | 11.9                             | 9.996                           |
| Gear Ratios ... ..      | 5.375, 8.44, 13.28 and 20.37 to 1 | 4.89, 7.68, 12.08 and 18.53 to 1 | 5.25, 8.04, 12.78 and 21.1 to 1 |
| Fuel Capacity ...       | 8 gals.                           | 8 gals.                          | 6 gals.                         |
| Oil Capacity (sump) ... | 1 gal.                            | 1 gal.                           | $\frac{3}{4}$ gal.              |
| Cooling Capacity ...    | 3 gals.                           | 2 $\frac{1}{4}$ gals.            | 2 $\frac{1}{4}$ gals.           |

## Engine Features.

The engine is in unit with the gearbox and is flexibly mounted to the chassis at three points, two at the front and one behind the gearbox. The mountings are of live rubber in order to insulate vibration.

The valves are on the near side and the cylinder head is detachable. Pistons are a special aluminium alloy. All parts of the engine are readily accessible for adjustment.

**Exhaust.** The silencer and exhaust system are also insulated from the chassis by live rubber mountings, in order to minimise vibration, and reduce noise.

**Fuel Feed.** Fuel is carried in a rear tank and is fed to the carburetter by a mechanical pump driven off the crankshaft. A downdraught carburetter is provided. Cars for the British market have a carburetter intake silencer and Export cars have an air cleaner. An electric fuel gauge is provided at the instrument board.

**Cooling.** A large fan, belt driven, draws air through a film-type radiator, and cooling is on the thermosyphon principle, controlled by an automatic thermostat. All cylinder barrels are separated by waterways.

**Lubrication.** A pressure gear pump forces oil to all main, big-end and crankshaft bearings, and oil consumption is very light.

**Ignition.** Coil and battery ignition is employed, with automatic advance and retard mechanism incorporated in the distributor head. Adjustment by pointer and scale is very simple.

**Clutch.** A new type of flexible clutch is employed, to assist easier changing and to give particularly smooth power take-up. The two friction rings are carried by the centre plate and held apart by leaf springs. Heat is rapidly dissipated to the plate.

**Gearbox.** The gearbox has four forward speeds and a reverse. The gear lever is centrally mounted on a ball and socket control, and, with synchromesh engagement for second, third and top, gear changes are very light and positive. The gears are silent in operation.

*Synchromesh for Second, Third and Top Speeds.*

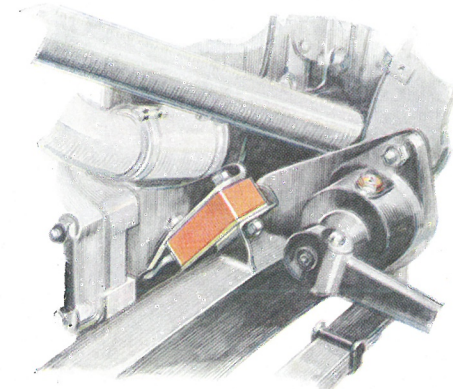
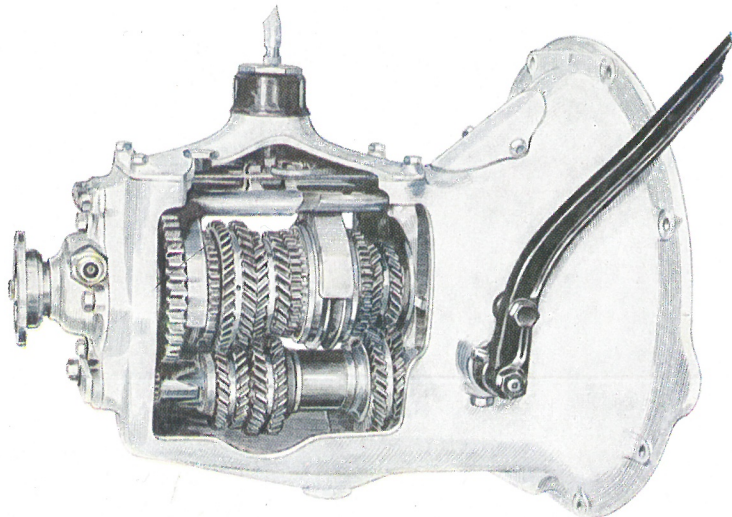

*Hydraulic Shock Absorbers.*

*Rubber Engine Mountings.*

# SPECIFICATION

## Chassis Features.

Rigidity of the main frame is assured by the provision of full-length deep side members, with adequate cross members and cruciform centre members, and the entire frame assembly is strongly welded.

**Suspension.** The long and supple semi-elliptic springs are controlled by double-acting Luvax hydraulic shock absorbers, and for Home sales are mounted on Silentbloc rubber bushes, which do not require lubrication. Export springs, which are stronger and have more camber, have special screw type shackles and Luvax shock absorbers.

The springs on the "Twelve" and "Fourteen" have zinc interleaving and self-lubricating anti-friction discs.

**Brakes.** The Girling wedge-and-roller brakes are mechanically operated and are light in application, but smooth, progressive and very powerful. Automatic compensation is provided between front and rear brakes, to minimise the possibility of skidding. Front brakes are operated by direct linkage and rear brakes through a strong spring, so that the retarding effect is adjusted according to conditions as weight is transferred to the front axle.

**Wheels.** Wire wheels or easy clean pressed steel spoke wheels, with large centres, can be fitted as desired. Extra Low Pressure tyres are standard, 5.75—16 on Twelves and Fourteens and 5.25—16 on Tens.

**Jacking.** Special pads are provided on the road springs to facilitate easy jacking.

**Steering.** Of the "hour-glass" worm and sector type, the steering is very light and responsive and very definite. Full adjustments are provided.

The **Goodwood** has a telescopic steering wheel adjustable over a range of three inches, and the **Cambridge** and **Conway** have a steering column of extra low rake. The horn button is mounted at the centre of the steering wheel and the direction indicator control immediately above it.

**Lubrication** of the chassis is by grease gun and the number of points has been reduced to a minimum. There are no road spring nipples, except on certain export cars.

## Equipment.

Standard equipment includes a twelve-volt electric lighting, starting and ignition set. The dynamo is fan ventilated and has automatically-compensated charging control.

Head and side lamps are chromium plated, except on special models, and the head lamps beams are controlled by a foot-operated dip-and-switch mechanism. The electric horn is rubber mounted and two combined stop and tail lights are provided. The starter motor is operated through a button and a solenoid switch, and starting is assisted by a combined strangler and throttle control.

The instrument board has an eight-day clock, magnetic type needle speedometer with trip and total readings, oil and petrol gauges, ammeter, lighting and ignition switch box, ignition warning lamp, starter button, sockets for an inspection lamp plug, and indirect lighting.

Full width bumpers are fitted front and rear, and blank number plates, spare wheel and tyre and a comprehensive set of tools are provided.

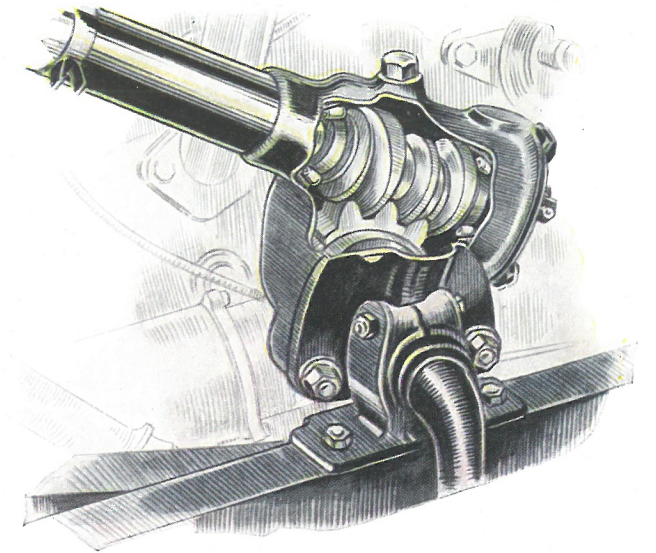

*Light and Positive Hour-glass Steering.*

*Long Supple Springs.*

*Smooth Girling Brakes.*

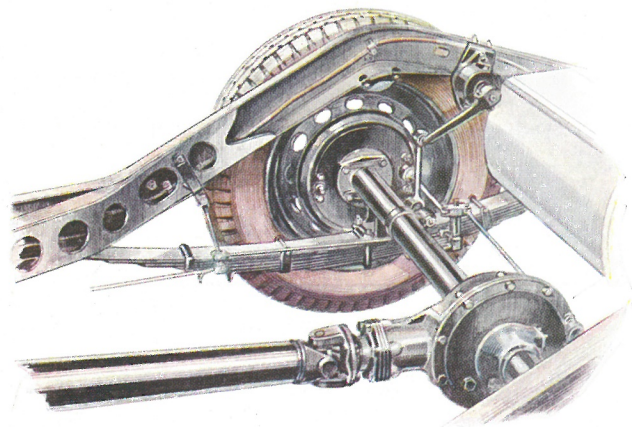

*Strong Cruciform Frame Bracing.*

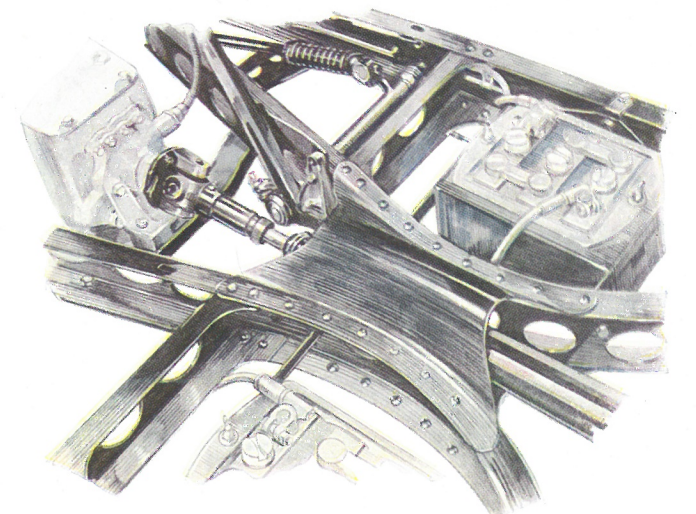

# LEADING DIMENSIONS

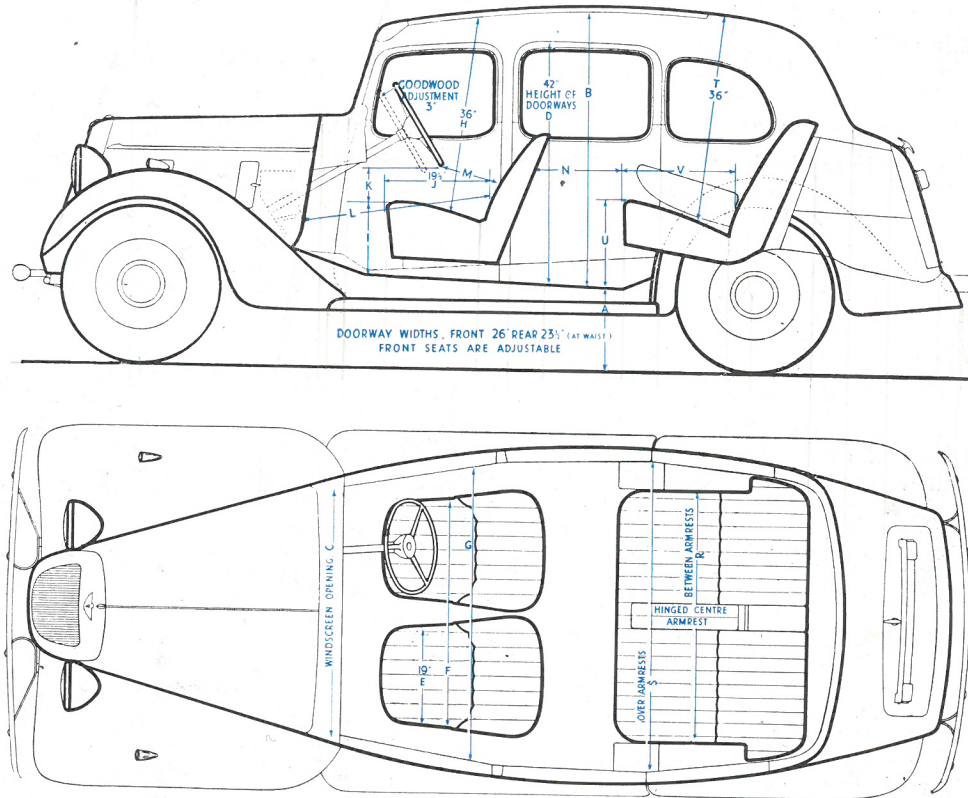

GOODWOOD NEW ASCOT CAMBRIDGE

|                                    |                                           |                       |                       |
|------------------------------------|-------------------------------------------|-----------------------|-----------------------|
| Wheelbase ... ..                   | 9' 3 $\frac{3}{4}$ "                      | 8' 10 $\frac{1}{4}$ " | 7' 9 $\frac{3}{8}$ "  |
| Track, Front ... ..                | 4' 2 $\frac{1}{4}$ "                      | 4' 2 $\frac{1}{4}$ "  | 3' 9 $\frac{3}{8}$ "  |
| Track, Rear ... ..                 | 4' 5 $\frac{1}{2}$ "                      | 4' 5 $\frac{1}{2}$ "  | 3' 10 $\frac{1}{2}$ " |
| Length over bumpers ... ..         | 14' 6"                                    | 14' 0"                | 12' 10"               |
| Length without bumpers ... ..      | 14' 0"                                    | 13' 6"                | 12' 5"                |
| Overall width ... ..               | 5' 3 $\frac{1}{2}$ "                      | 5' 3 $\frac{1}{2}$ "  | 4' 9"                 |
| * Height, with sliding roof ... .. | 5' 5 $\frac{1}{2}$ "                      | 5' 5 $\frac{1}{2}$ "  | 5' 4"                 |
| * Height, with ventilator ... ..   | 5' 6 $\frac{1}{2}$ "                      | 5' 6 $\frac{1}{2}$ "  | 5' 5"                 |
| * Height, ventilator open ... ..   | 5' 11"                                    | 5' 11"                | 5' 9 $\frac{1}{2}$ "  |
| Ground Clearance, Home ... ..      | 6 $\frac{3}{4}$ "                         | 6 $\frac{3}{4}$ "     | 6 $\frac{3}{8}$ "     |
| Ground Clearance, Export ... ..    | 7 $\frac{3}{4}$ "                         | 7 $\frac{3}{4}$ "     | 6 $\frac{3}{8}$ "     |
| A Ground to floor ... ..           | 14"                                       | 14"                   | 13 $\frac{3}{8}$ "    |
| B Floor to roof ... ..             | 47 $\frac{1}{2}$ "                        | 47 $\frac{1}{2}$ "    | 46 $\frac{3}{8}$ "    |
| C Windscreen width ... ..          | 42 $\frac{1}{4}$ "                        | 42 $\frac{1}{4}$ "    | 36"                   |
| Rear Doorway, at waist ... ..      | 23 $\frac{1}{2}$ "                        | 23 $\frac{1}{2}$ "    | 23 $\frac{3}{8}$ "    |
| Front Doorway, at waist ... ..     | 26"                                       | 26"                   | 26 $\frac{3}{8}$ "    |
| D Doorway height ... ..            | 42"                                       | 42"                   | 42"                   |
| E Front seat cushion ... ..        | 19"                                       | 19"                   | 19"                   |
| F Front seat width ... ..          | 43"                                       | 43"                   | 41"                   |
| G Front waist width ... ..         | 52 $\frac{1}{2}$ "                        | 52 $\frac{1}{2}$ "    | 46"                   |
| H Front seat to roof ... ..        | 36"                                       | 36"                   | 36"                   |
| I Front seat to floor ... ..       | 13 $\frac{1}{2}$ "                        | 13 $\frac{1}{2}$ "    | 12 $\frac{1}{2}$ "    |
| J Front seat depth ... ..          | 19 $\frac{1}{2}$ "                        | 19 $\frac{1}{2}$ "    | 19 $\frac{1}{2}$ "    |
| Steering Adjustment ... ..         | 3"                                        | —                     | —                     |
| L Pedal to squab, max. ... ..      | 42"                                       | 42"                   | 42"                   |
| L Pedal to squab, min. ... ..      | 34 $\frac{1}{2}$ "                        | 34 $\frac{1}{2}$ "    | 34 $\frac{1}{2}$ "    |
| M Squab to wheel, max. ... ..      | 18"                                       | 17"                   | 17"                   |
| M Squab to wheel, min. ... ..      | 8"                                        | 9 $\frac{1}{2}$ "     | 9 $\frac{1}{2}$ "     |
| N Knee room, max. ... ..           | 18 $\frac{3}{8}$ "                        | 18 $\frac{3}{8}$ "    | 14"                   |
| N Knee room, min. ... ..           | 11"                                       | 11"                   | 6 $\frac{3}{8}$ "     |
| Front seat to wheel ... ..         | { 6 $\frac{3}{8}$ " (max.)<br>5" (min.) } | 5 $\frac{1}{2}$ "     | 5 $\frac{1}{2}$ "     |
| R Rear seat width ... ..           | 44 $\frac{1}{2}$ "                        | 44 $\frac{1}{2}$ "    | 39 $\frac{1}{2}$ "    |
| S Seat over arm-rests ... ..       | 52 $\frac{1}{2}$ "                        | 52 $\frac{1}{2}$ "    | 47 $\frac{3}{8}$ "    |
| T Rear seat to roof ... ..         | 36"                                       | 36"                   | 36"                   |
| U Rear seat to floor ... ..        | 15"                                       | 15"                   | 14 $\frac{1}{2}$ "    |
| V Rear seat depth ... ..           | 20"                                       | 20"                   | 19 $\frac{3}{8}$ "    |

\* Normal loads, Home Market. Export springs increase height and ground clearance.

The fitted trunk is approximately 30" long, 12" wide (minimum) and 10" deep.

## AFTER SALES SERVICE

**EVERY AUSTIN DEALER** is under agreement to provide "After Sales Service" to Austin cars purchased from him. During the period of the first thousand miles running of such cars he will, without charge, inspect and if necessary:

Adjust Brakes.

Oil and Grease all points of the car.

Check and correct Carburetter Mixture.

Check and correct Ignition Timing and Tappet Clearances.

Drain Crankcase, Gearbox and Back Axle, and Refill.

Reset Slow Running Adjustment.

Tighten Cylinder Head Nuts.

Check Front Wheel Alignment.

Examine Battery and bring up to proper level with

Distilled Water or Diluted Acid, as may be required.

Tighten all Nuts and Bolts on the Body, Steering Springs, etc.

Examine all Wires and Terminals.

Adjust Clutch and Brake Pedals.

Adjust Fan Belt.

Test the Tyres for Correct Pressure.

Clean Dynamo Commutator.

All materials will be charged for.



# THE OTHER DEPENDABLE AUSTINS

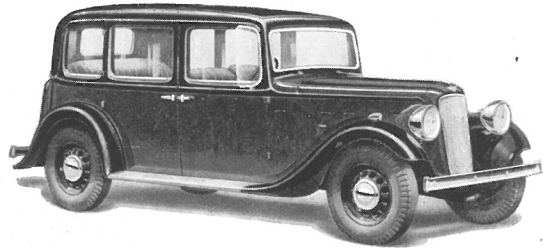

Hertford Saloon,

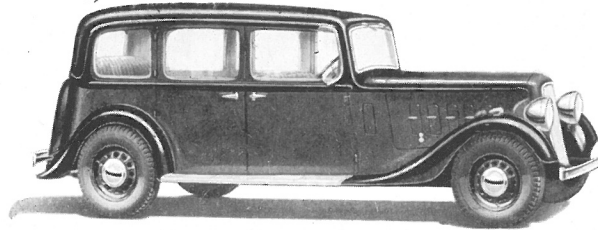

Mayfair Limousine,  
Mayfair Landaulet,

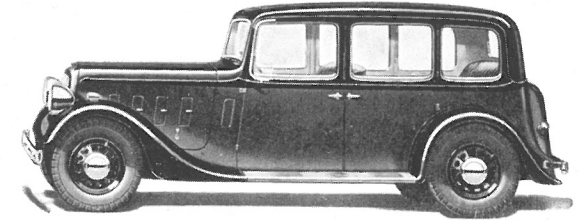

York Saloon,  
Chalfont Saloon,

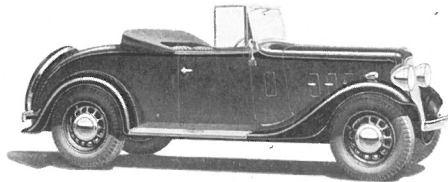

Austin Two-Seaters  
Ten-Four,  
Twelve-Four,  
Twelve-Six,

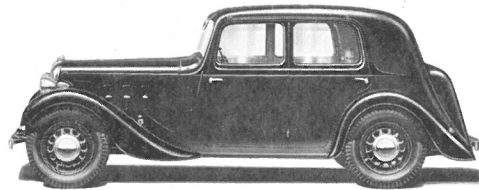

The New Kempton Saloon  
Standard Engine      Sports Engine

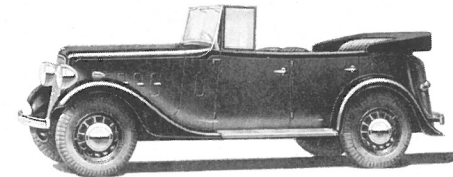

Austin Tourers  
Ten-Four,  
Twelve-Four,  
Twelve-Six,

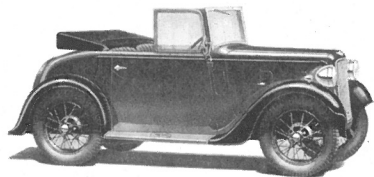

Seven Two-Seater

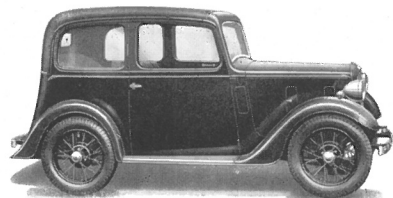

The Pearl Cabriolet  
Folding Hood

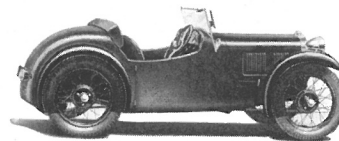

Nippy-Two-Seater  
Standard Engine      Sports Engine

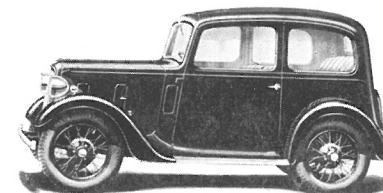

New Ruby Saloon  
Fixed Head      Sliding Roof

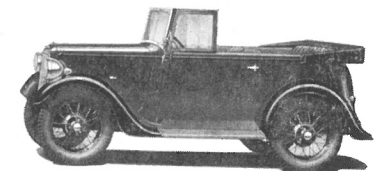

Seven Tourer

FOR DETAILS OF OTHER DEPENDABLE AUSTINS SEE SEPARATE PUBLICATIONS.

# THE MANUFACTURERS' WARRANTY

THE goods manufactured by the Austin Motor Company Limited (hereinafter called "the Company") are supplied with the following express Warranty which excludes all warranties conditions and liabilities whatsoever implied by Common Law Statute or otherwise that is to say:—

In the event of any defect being disclosed in any part or parts of the goods and if the part or parts alleged to be defective are returned to the Company's Works carriage paid within six months from the date when the goods are delivered new to the retail customer the Company undertakes to examine same and should any fault due to defective materials or workmanship be found on examination by the Company it will repair the defective part or supply free of charge a new part in place thereof. This Warranty is limited to the delivery to the Purchaser free at the Company's Works of the part or parts whether new or repaired in exchange for those acknowledged by the Company to be defective.

The Company gives no warranty of the goods except as herein stated but desires and expects that customers shall make a thorough examination before purchasing. Persons dealing in the Company's goods are in no way the legal Agents of the Company and have no right or authority to assume any obligations on its behalf express or implied or to bind it in any way.

For the purpose of this Warranty the term "goods" means and includes new cars or vans or chassis or parts thereof including replacement parts manufactured by the Company. It does not include tyres speedometers or electrical equipment or other proprietary articles or goods (including coach work) not of the Company's own manufacture although supplied by the Company. Proprietary articles are covered by the warranty (if any) given by the separate manufacturers. On second-hand goods no warranty is given by the Company or is to be implied.

The Company's responsibility is limited to the terms of this Warranty and it shall not be answerable for personal injuries or consequential or resulting liability damage or loss arising from any defects. This Warranty shall not apply to defects caused by motor racing wear and tear misuse or neglect or to the defects in any goods which have been altered outside the Company's Works or which have been let out on hire or the identification numbers or marks on which have been altered or removed. This Warranty is dependent upon the strict observance by the Purchaser of the following provisions:—

The Purchaser shall at the time of purchase personally sign the form supplied by the Company and register his name address date of purchase price paid and car and chassis numbers and name and address of Seller with the Company and shall obtain from the Company a signed copy of this Warranty and shall produce same to the Company's representative for inspection in case of any claim being made. This Warranty shall not be assigned or transferred to anyone unless the Company's consent in writing has first been obtained.

The Purchaser shall send to the Company's Works such part or parts as are alleged or claimed to be defective promptly on the discovery of the claimed defect. Transportation is to be prepaid by the Purchaser and said part or parts to be properly packed for transit and clearly marked for identification with the name and full address of the Purchaser and with the car and chassis numbers of the vehicle from which the said part or parts were taken. The Purchaser shall post to the Company at its Works on or before despatch of such part or parts alleged to be defective a full and complete description of the claim and the reasons therefor. The judgment of the Company in all cases of claims shall be final and conclusive, and the Purchaser agrees to accept its decision on all questions as to defects and to the exchange of part or parts. After the expiration of six days from the despatch of notification of the Company's decision the part or parts submitted may be scrapped or returned carriage forward by the Company.

## TERMS OF BUSINESS

**PRICES:** The Company reserves the right to vary the list prices at any time and all goods are invoiced at the prices current on day of delivery. Should the price be increased prior to delivery the Purchaser has the option of cancelling the order within seven days after being notified of such increase and of calling for the return of his deposit which shall be accepted in satisfaction of all claims.

**DEPOSIT:** A deposit of £25 is to accompany the order for each vehicle.

**SPECIFICATION:** The Company reserves the right on the sale of any vehicle to make before delivery without notice any alteration to or departure from the specification design or equipment detailed in this catalogue. Triplex toughened glass will be generally

fitted, but the Company will if supplies are not available substitute another make of glass approved by them.

**DELIVERY:** At the Company's Works, Longbridge, Birmingham. The Company is not responsible for damage occurring after delivery. The cost of transport (if any) thence to destination is payable by the Purchaser. The Company shall not be liable in any way for delay in delivery from any cause whatsoever.

**COUNTERFEIT PARTS:** All goods manufactured by the Company are sold with the express warranty printed in the current catalogue which excludes all warranties conditions and liabilities implied by the Common Law Statute or otherwise. The use on any vehicle of the Company's manufacture of replacement parts not made by or for the Company will invalidate the Warranty.

## THE AUSTIN MOTOR COMPANY LTD.

LONGBRIDGE,

BIRMINGHAM,

ENGLAND

Telephone :

Priory 2101  
(20 lines).

Telegrams :

"Speedily, Telex,  
Northfield."

Cablegrams :

"Speedily, Birmingham,  
England" (Bentleys).

Correspondence :

G.P.O. Box 41  
Birmingham.

LONDON SHOWROOMS: 479-483, Oxford Street, W.1  
(near the Marble Arch).

Telephones : Mayfair 7620 (18 lines)

Telegrams : "Austinette, Telex, London."